

# iSTS

## Model C User Manual

Wall Mount Static Transfer Switch

Last Updated  
16/11/18

---

# Contents

<b>1 Safety Instructions .....</b>	<b>3</b>
1.1 Introduction.....	3
1.2 Transport, Storage, Unpacking.....	3
1.3 Installation .....	3
1.4 Electrical Connection.....	4
1.5 Synchronism.....	4
1.6 Fire Regulations .....	5
1.7 Standards Applied & Conformity.....	5
1.8 Warranty .....	6
<b>2 System Overview.....</b>	<b>7</b>
2.1 Description.....	7
2.2 Single Line Diagram – Single-Phase 2-Pole Models .....	8
2.3 Single Line Diagram – Three-Phase 4-Pole Models.....	8
2.3 Front Interview View .....	9
<b>3 Installation.....</b>	<b>10</b>
3.1 Environment Check .....	10
3.2 Connecting to Terminals.....	11
3.3 Commissioning.....	12
<b>4 User Interface Panel .....</b>	<b>14</b>
4.1 Preferred Switch .....	14
4.2 Override Switch .....	14
4.3 Remote Connection Port - High Density DA-26.....	15
<b>5 Display Screen Interface.....</b>	<b>16</b>
5.1 Front Panel Overview .....	16
5.2 Menu Screen Hierarchy.....	17
5.3 Status & Alarms Screen .....	18
5.4 Variables .....	18
5.5 Events List.....	19
5.6 Settings .....	19
5.7 Date & Time.....	20
5.8 Calibration .....	21
5.9 Communication Settings.....	21
5.10 Diagnostics.....	22
5.11 Utilisation.....	22

<b>6 Web Browser Interface</b> .....	<b>24</b>
6.1 Connecting to a PC .....	24
6.2 Connecting to the Web Server.....	25
6.3 Control Panel.....	26
6.4 Email .....	28
6.5 Advanced Settings.....	29
6.6 Input Steady State Settings .....	30
6.7 Input Transient Settings.....	32
6.8 Output Settings.....	34
<b>7 Maintenance Bypass</b> .....	<b>36</b>
7.1 Overview .....	36
7.2 Using the OVERRIDE switch.....	36
7.3 Maintenance Bypass Procedure.....	36
7.4 Reinstatement from Maintenance Bypass Procedure.....	37
<b>8 Fault Diagnosis</b> .....	<b>39</b>
8.1 Fault Codes .....	39
8.2 Load Fault.....	41
<b>9 Maintenance</b> .....	<b>42</b>
<b>10 Specifications</b> .....	<b>43</b>
<b>11 Operating Parameters</b> .....	<b>44</b>
<b>12 Contact Information</b> .....	<b>45</b>

# 1 Safety Instructions

## 1.1 Introduction

Some aspects of this manual's contents may differ to the equipment as supplied due to technical improvements, specific model variations etc. If in any doubt in respect to the procedures and safety issues consult the manufacturer and do not proceed until clarification is received.

This manual contains important instructions that should be followed and fully understood before proceeding and commissioning and operation to prevent harm to personnel and equipment.

Installation and commissioning should be carried out only by qualified and experienced electricians. The STS should be operated by technically qualified personnel that are authorized, experienced and have knowledge and understanding of the equipment and the critical loads, using the documented procedures.

Read this whole document thoroughly. Understand every aspect before proceeding. Request further assistance if you do not understand any aspect of the operation of the STS. Support and contact numbers are at the end of the manual.

These instructions cover normal operation in the automatic as well as in manual modes. Special operating conditions, such as short circuit tests, input supplies, etc., are not covered in this document. These operations require comprehensive knowledge of the overall system and should be carried out by properly qualified, skilled and competent service personnel only.

## 1.2 Transport, Storage, Unpacking

The STS has been fitted with Shockwatch ship drop sensor in an effort to reduce transit damage and safeguard our shipments.

### **Procedure for Receiving Shipment:**

- Please do not refuse to accept shipment. An activated (RED) indicator on the label does not mean that damage has occurred. It only indicates that the carton received an impact or movement above a normal anticipated level. Only an inspection can determine if any damage has occurred. If the indicator on the label is RED, please make a notation to that effect on the bill of lading or delivery receipt or document. Examine contents immediately for possible damage. If damage is discovered, inform carrier immediately and follow normal procedure for a carrier inspection and filing of a concealed damage claim.
- Take a picture of the carton and contents as a record.
- If the packaging is OK then please keep the packaging in a secure place in case the unit needs to be returned for repair.

## 1.3 Installation

The following instructions are provided for the personal safety of operators and also for the protection of the described product and connected equipment.

- Observe the prescribed accident prevention and safety rules for the specific application.

- When installing the STS strictly observe all information on technical data and operating conditions. Comply with all warnings, and strictly follow the procedures and practices as described in this manual.
- This STS is intended to be used in a controlled indoor environment and free of conductive contaminants and protected against animal intrusion.
- It is important that the unit has adequate ventilation. Maintain air movement around and through the unit. Do not block the air vents or restrict airflow over the heatsinks on the side of the STS.
- The unit must be placed in a sufficiently ventilated area; the ambient temperature should not exceed 40°C (104°F).
- Do not install the STS in an excessively humid environment or near water, relative humidity should not exceed 90% at 20°C (68°F).
- Avoid spilling liquids or dropping any foreign object into the STS.
- The electrical connections must be covered.
- Connecting cables must be supported.
- Earth connection must be checked for safe function after assembly.

## 1.4 Electrical Connection

- Cable lug size is limited to 35/50 mm<sup>2</sup> or 70 mm<sup>2</sup> using narrow palm lugs and 10 Amps per terminal.
- All cables connecting to the STS should be supported and not weigh the rear of the STS and strain the point of connection at the front of the STS.
- All electrical connections are to be realized by properly qualified, skilled and competent service personnel only.
- Consider electrical distribution discrimination carefully. The STS has two incoming AC power sources; your upstream protective devices must discriminate with downstream protective devices. The upstream STS supply breaker /fuse should only open if the downstream device protection is unable to trip or there is a fault within the STS.

## 1.5 Synchronism

The smoothest change-over occurs when the supplies are in synchronism. If an asynchronous transfer occurs, large currents may flow into the load which can damage trip & protective devices, blow fuses, saturate and cause damage to transformers. If possible it is best to make sure the supplies are in synchronism.

## 1.6 Fire Regulations

Should a fire break out inside the system a fire extinguisher with CO<sub>2</sub> or halogen must be used. Do not inhale vapours.

## 1.7 Standards Applied & Conformity

This equipment conforms to the following standards and EC Directives:

Standards to which conformity declared:

EN 60950-1	Information technology equipment Safety - General requirements
EN/AS 62310.1	Static transfer systems (STS) - General and safety requirements
EN/AS 62310.2	Static transfer systems (STS) - Electromagnetic compatibility (EMC) requirements
EN/AS 62310.3	Static transfer systems (STS) - Part 3: Method for specifying performance and test requirements
EN/AS 55024	Information technology equipment, Immunity characteristics, Limits and methods of measurement
EN 60950-1-2006	Information technology equipment safety: General requirements

### Application of Council Directives:

2006/95/EC	Low Voltage Directive
73/23/EEC	Low Voltage Directive
89/336/EEC	EMC Directive, in version 92/31/EU
93/68/EEC	EMC Directive Amendments

The product mentioned in this manual conforms to the relevant requirements to the appropriate EU Directive, i.e. that this product meets all relevant EU Directives and that it can be sold inside the European Union without national commercial hindrances.

Relevant EU Directives: EMC- and Low Voltage Directives:

- EU Directive on Electromagnetic Compatibility 89/336/EU, in version 92/31/EU, 93/68/EU
- EU Directive on Electrical Equipment designed for use within certain Voltage Limits (Low Voltage Directive) 73/23/EU, in version 93/68/EU

The directives themselves define only on a modest scale what to do and refer to the harmonised standards. One of the EU harmonised product standards is applicable for rectifier systems.



**The standards mentioned above fulfil the requirements for CE marking.**

## **1.8 Warranty**

Static Power operating through its authorized agents warrants that the standard products will be free of defects in materials and workmanship for a period of 24 months after the date of invoice, or such other period as may be specified.

This warranty does not cover failures of the product which result from incorrect installation, misuse, alterations by persons other than authorized agents or abnormal operating conditions.

## 2 System Overview

### 2.1 Description

A Static Transfer Switch (STS) provides seamless switching between two power sources to provide uninterrupted power to a critical load.

The STS continuously monitors the supply sources for failure or degeneration and switches automatically to the alternate source if the load will be affected. The break in the supply transition is so short that it is not seen by the critical load. This switching process is undertaken as a **break before make** transfer, preventing overlapping which can cause large and unpredictable currents. Both the active conductor and the neutral are switched. Thyristors are used to undertake the switching process.

In the case of downstream load fault conditions, the fault current drawn from the supply may degrade or damage the supply sources; as a consequence should a fault current exist in the load the STS will inhibit a transfer to the alternate source even if this causes source supply degradation or loss. This is to ensure that the fault will not be transferred to the alternate supply with the possibility of degrading both sources.

The current threshold for isolation is pre-set to approx. 300% of the rated current.

This unit contains fuses. The fuses are to provide for safe operation even in high fault capacity environments. It should be noted that the fuses are for the protection of the semiconductor switches (SCRs/ Thyristors), not the load. The STS does not have any automatic tripping devices, so load discrimination is undertaken in the primary and secondary supply networks.



## 2.2 Single Line Diagram – Single-Phase 2-Pole Models

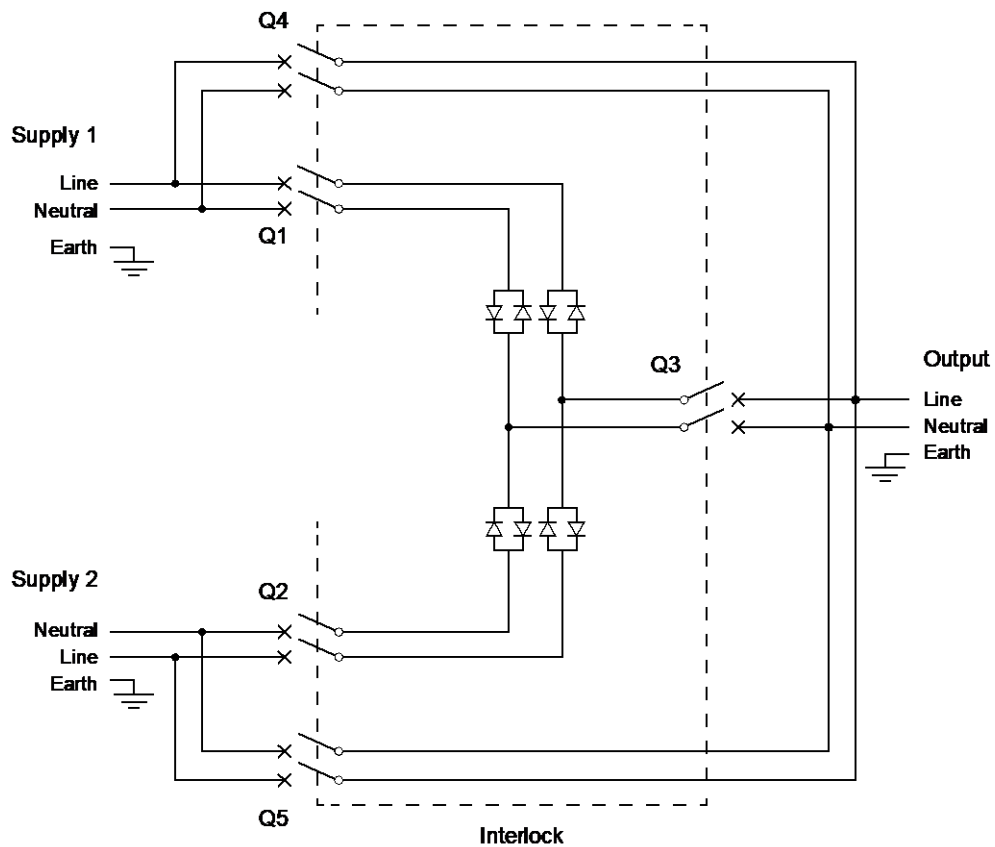

## 2.3 Single Line Diagram – Three-Phase 4-Pole Models

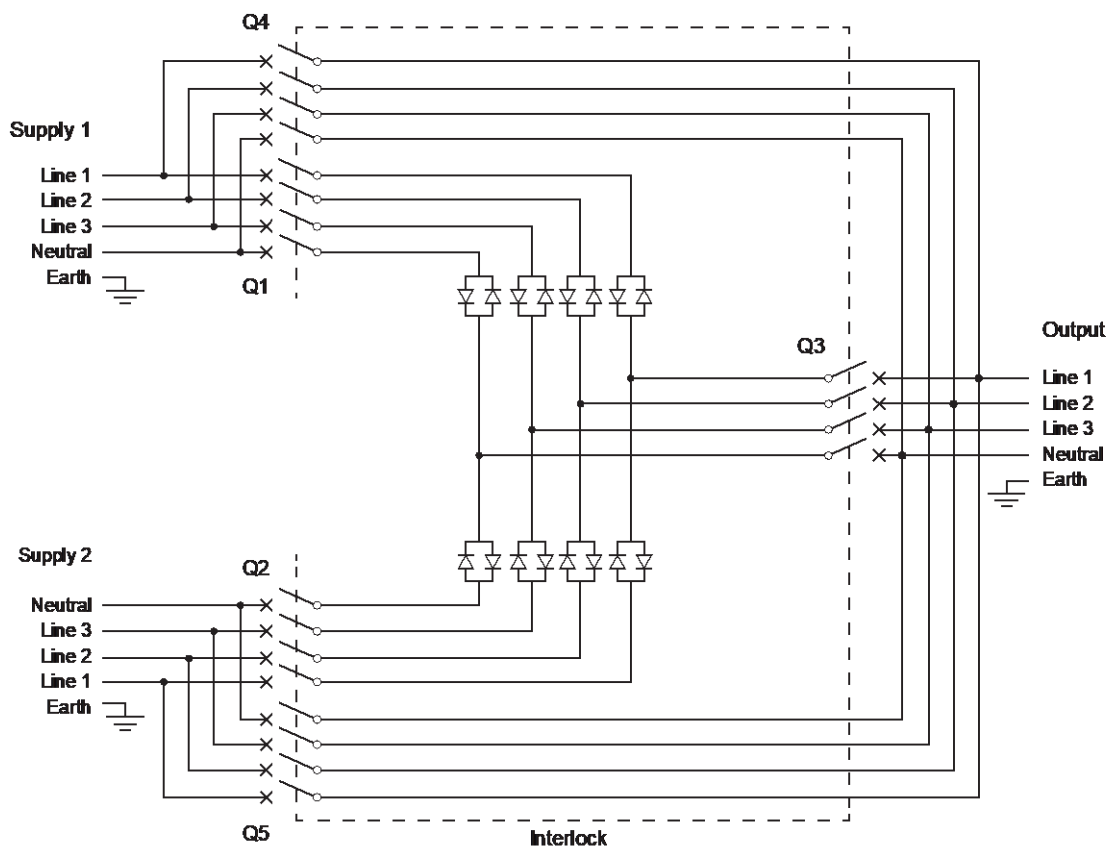

## 2.3 Front Interview View

The STS includes a mechanically interlocked maintenance bypass via a 5 x circuit breaker array.

### TOP CABLE ENTRY

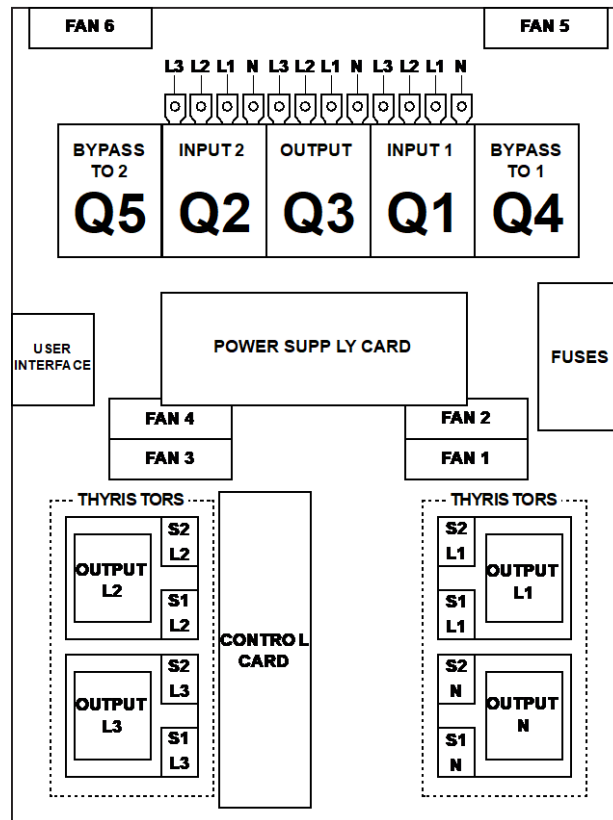

### BOTTOM CABLE ENTRY

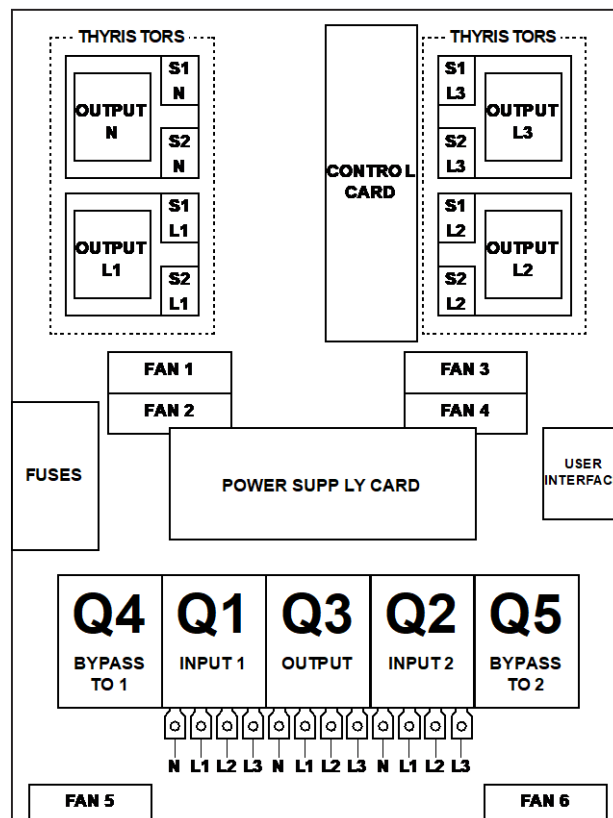

## 3 Installation

### 3.1 Environment Check

It is important that the STS is installed into an environment that adheres to the following set of specifications:

Environmental Parameters	Min	Max
Temperature	-20°C	40°
Humidity	5%	90%

- The STS unit should be bolted to the wall using the provided mounting rails.
- The STS should have clearance of at least 300mm above and 200mm below the enclosure for ventilation.
- The STS should be mounted so that the LCD and decal interface is around 160mm from the ground (average eye level) for ease of access.

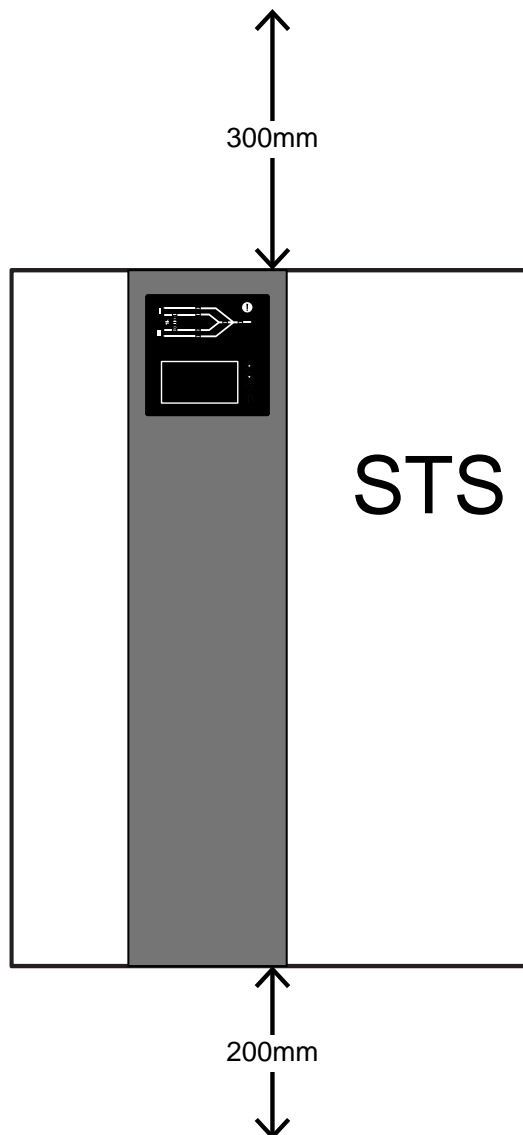

## 3.2 Connecting to Terminals

It is important that the cables are run in accordance with any local regulations. The cable entry space may be at the top or bottom depending on the unit. The gland plate covering the cable entry space must have a hole cut into it to fit the cable runs. All data cable is run to the User Interface panel. The data cables should not be run close to the power cables (>50mm).

It is important that all cables are terminated using lugs and that the lugs are fastened to the terminals with the supplied bolts. The terminals will accommodate a standard M8 cable lug (up to 70 mm<sup>2</sup> or 95 mm<sup>2</sup> using narrow palm lugs).

The bolts should be torqued to 10Nm (7.5lb ft). Once the cables have been terminated, care should be taken to double check that the cables have been placed in the correct position.

### TOP CABLE ENTRY

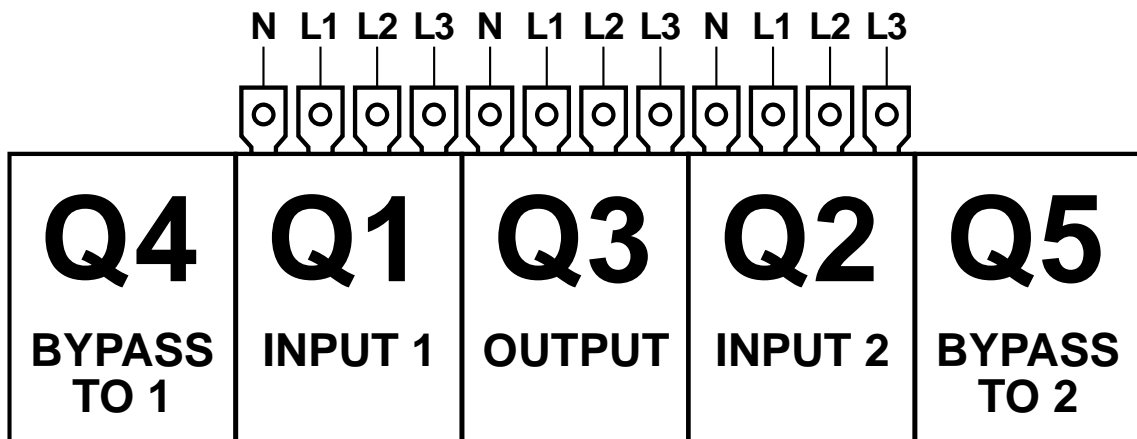

### BOTTOM CABLE ENTRY

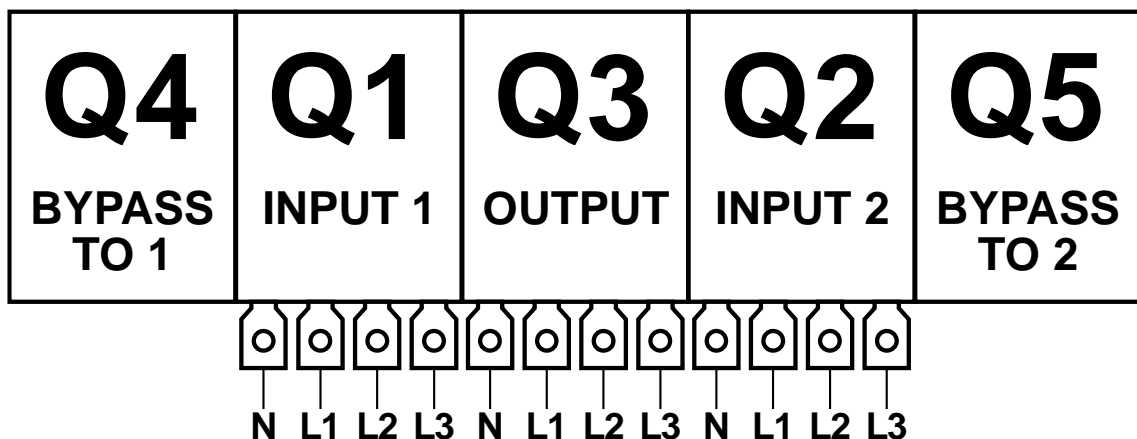

### 3.3 Commissioning

**Power-up Test:** This section covers the steps required for the initial power up of the STS. As always care should be taken when dealing with live voltages. A test load of at least 15A is required. You can use the Commissioning Checklist on the next page to assist you.

1. Start with both input supplies off. If the unit has isolation breakers these should be off.
2. Connect Load.
3. Turn on Supply 1 (S1) and measure the voltages across the phases to neutral. Check that the electronics starts-up. Then turn S1 off.
4. Turn on Supply 2 (S2) and measure the voltages across the phases to neutral. Check that the electronics starts-up. Then turn S2 off.
5. Turn on Q1 and Q2.
6. Turn on S1; check the voltages on the User Interface (UI) LCD.
7. Turn on S2; then check voltages on the UI LCD.
8. Turn on Q3; input supply may dip causing a transfer.
9. With the unit on S1 (manually transfer if necessary); measure the voltage of the output and measure the current/load on each phase.
10. Confirm these values on the UI LCD.
11. Transfer to S2; Measure the voltage of the output and measure the current/load on each phase.
12. Confirm these values on the UI LCD.
13. Simulate supply failures and observe the unit transfer: ie. While on S1, fail S1; while on S2, fail S2. Observe that the STS transfers okay.
14. Review the event list. Taking note of any COMMS or SCR events.

**After initial power up:** After a few seconds the display screen will power up and you will be prompted to enter the date and time. We strongly encourage the setting of the date and time so that real time event correlation can be undertaken. The Real Time Clock is backed up by a battery clock.

The ALARM should not be active. If it is check the following states:

- ON Supply 1 when priority is Supply 2
- ON Supply 2 when priority is Supply 1
- Supply 1 or Supply 2 are not in spec.
- Override Switch is in position 1 or 2
- Supply 1 & 2 are not in synchronism
- The unit is too hot (thermal bi-metal switch on H.S. activated)
- There is / was an overcurrent/ overload / load fault condition

#### Commissioning Checklist

<b>Environment</b>		
Temperature	Min: -20° Max: 40°	
Humidity	Min: 5% Max: 90%	
IP rating	Water and Dust hazards	

<b>Situating</b>		
Positioning		
Mounting		

<b>Cabling</b>		
Power		
Data		
Terminated		
Checked		

<b>Power-up Test</b>						
Input supplies and Breakers OFF						
Connect Load						
Turn on S1	L1 V=	L2 V=	L3 V=	Electronics		
Turn off S1						
Turn on S2	L1 V=	L2 V=	L3 V=	Electronics		
Turn off S2						
Turn on breakers Q1 & Q2						
Turn on S1: UI LCD Voltages						
Turn on S2: UI LCD Voltages						
Turn on Q3						
S1 to Output:						
L1 V=	L2 V=	L3 V=	L1 I=	L2 I=	L3 I=	N I=
UI LCD Voltage and Currents						
S2 to Output:						
L1 V=	L2 V=	L3 V=	L1 I=	L2 I=	L3 I=	N I=
UI LCD Voltage and Currents						
Event List Check						

## 4 User Interface Panel

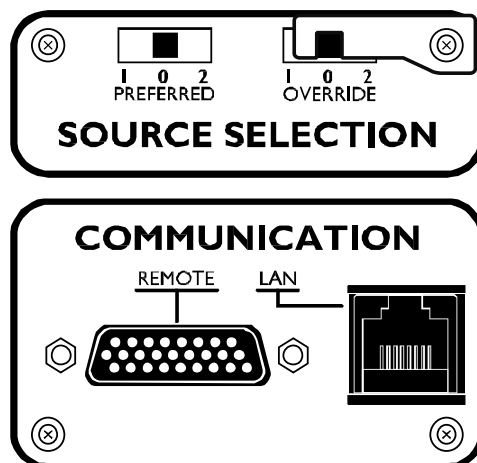

### 4.1 Preferred Switch

This switch allows the preferred source to be set to Supply 1, Supply 2 or None (0), which will take affect **only** when the preferred source is set to None (0) on the STS software. Refer to the Web Browser Interface section for instructions on changing the preferred source through LAN connectivity.

If the STS is forced to automatically transfer the critical load to the alternate source the STS will automatically transfer back to the preferred again when the preferred source is within tolerance and after a pre-set settling delay.

### 4.2 Override Switch

Setting the override switch to 1 or 2 will force the STS to stay on that supply even if faults are detected on that source. This switch overrides all other settings. It should not be used to transfer the critical load between sources (a break may result).

**NOTE:** The override provides control logic bypass only, it does not provide an alternative path for the load power.

**WARNING!** The override switch initiates instantaneous transfers and may transfer faults to the load.

**WARNING!** Never attempt to operate the OVERRIDE switch if the supplies are not in synchronism. There is no interlock to prevent the switch from being operated when the supplies are not available or not in synchronism. Refer to the LCD variables display and mimic diagram to check the synchronism state, (SYNC LED will be RED, variables display will show degrees out of synchronism. Only operate when less than 10 degrees). If the control is not operating you may need to use other means to determine that the supplies are in synchronism. Do not operate the OVERRIDE switch onto an absent supply.

### 4.3 Remote Connection Port - High Density DA-26

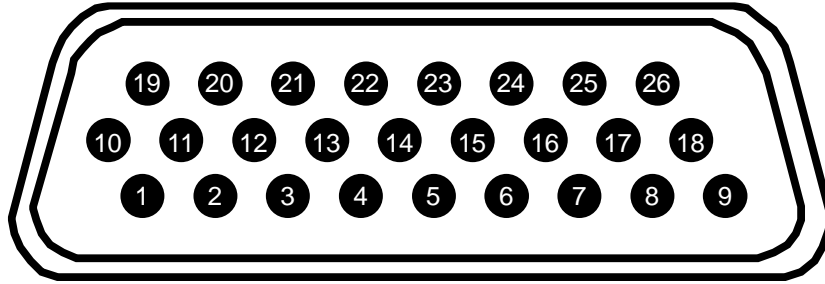

#### UI Breakout

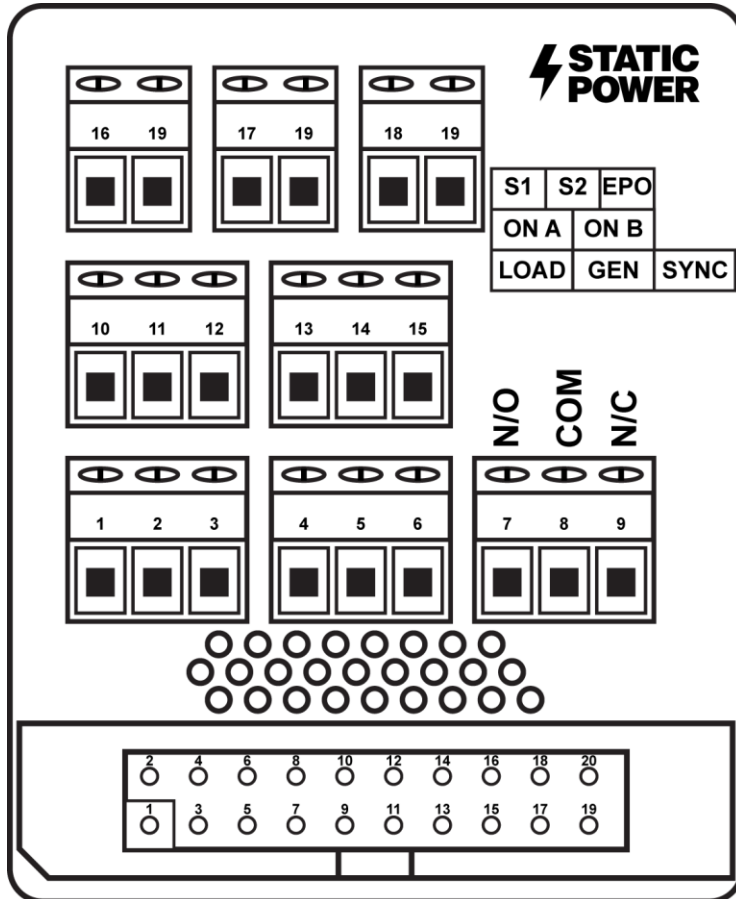

The relays can switch up to 220 DC, 250 AC.

Remote contacts are wet contacts and do not require external voltage to be applied.

PINS	CONNECTION	FUNCTION
1 to 2	N/O	Load Fault
3 to 2	N/C	Load Fault
4 to 5	N/O	General Alarm
6 to 5	N/C	General Alarm
7 to 8	N/O	Not in Sync
9 to 8	N/C	Not in Sync
10 to 11	N/O	ON A (Supply 1)
12 to 11	N/C	ON A (Supply 1)
13 to 14	N/O	ON B (Supply 2)
15 to 14	N/C	ON B (Supply 2)
16 to 19	REMOTE CONTACT	Emergency power off
17 to 19	REMOTE CONTACT	Transfer to Supply 1
18 to 19	REMOTE CONTACT	Transfer to Supply 2



# 5 Display Screen Interface

## 5.1 Front Panel Overview

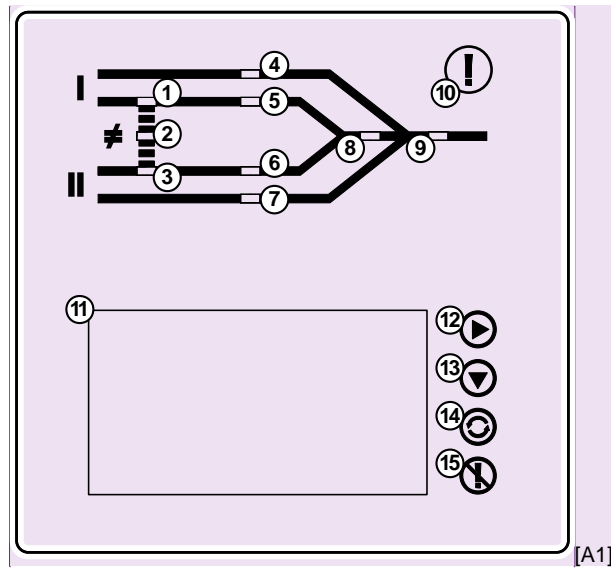

	Name	Description
1	Supply 1 Okay LED	Green/Red indicates that Supply 1 is within/out of tolerance
2	Sync Okay LED	Green/Red indicates whether Supply 1 and Supply 2 are within/not within synchronisation range to perform a transparent transfer
3	Supply 2 Okay LED	Green/Red indicates that Supply 2 is within/out of tolerance
4	Supply 1 Bypass LED	Green/Red the Supply 1 bypass is active/inactive. This corresponds to breaker Q4.
5	On Supply 1 LED	Green/Red indicates the load is on/not on Supply 1
6	On Supply 2 LED	Green/Red indicates the load is on/not on Supply 2
7	Supply 2 Bypass LED	Green/Red the Supply 1 bypass is active/inactive. This corresponds to breaker Q5.
8	Output Okay LED	Green/Red indicates the output is OK/faulty
9	Bypass LED	Green light will turn on if breaker Q3 is closed OR if bypass 1 or 2 (breakers Q4 & Q5) are closed. If open, LED is Red.
10	Alarm LED	Red light and audible alarm indicates a fault. Pressing the Alarm Cancel button will silence the alarm and the light will stay on until the fault is cleared. The fault will be recorded in the Events List.
11	LCD display	Shows Supply Status, Alarms, Settings, Events List and Settings. Refer to Menu Screens section for more information.
12	Next button	Press to enter a menu
13	Down button	Press to scroll through menus
14	Transfer supply button	Press to transfer to the alternate supply (to change the preferred supply remotely, refer to Control Panel in the Web Browser Interface section)
15	Alarm Cancel button	When a fault occurs, press to acknowledge alarm and turn off the audible alarm while. The Alarm LED will remain on until the fault is cleared.

## 5.2 Menu Screen Hierarchy

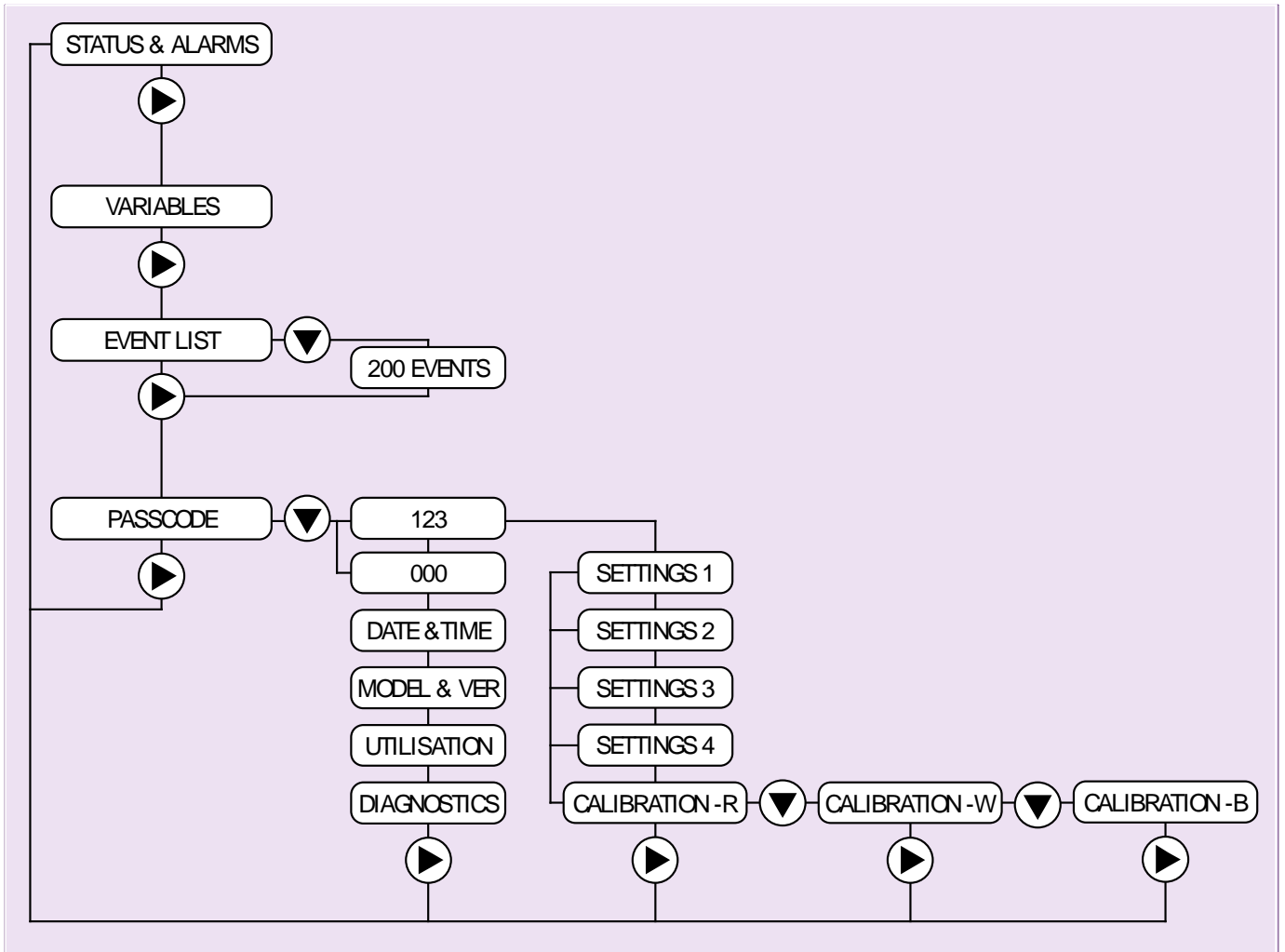

[A2]

This is the LCD menu hierarchy structure. The ► button exits the hierarchal tree and returns to the Status Screen. Use the ▼ button to enter a menu.

### 5.3 Status & Alarms Screen

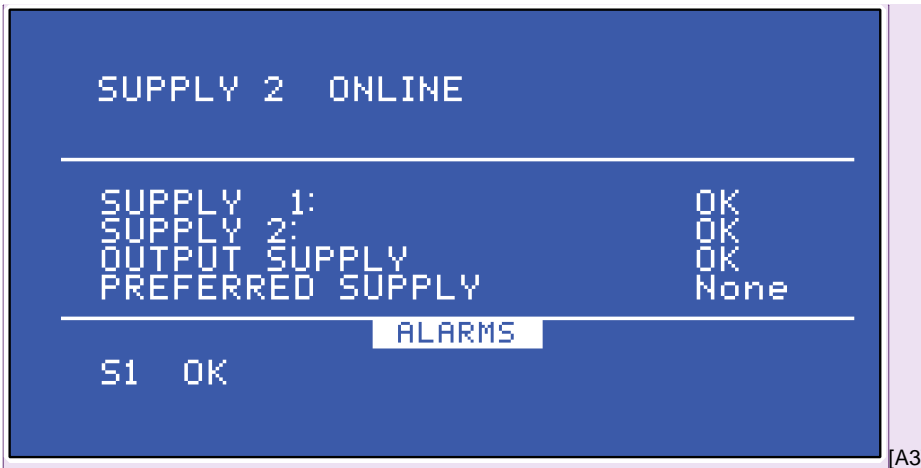

The Status & Alarms Screen shows the status of the STS status and the most recent fault alarm.

### 5.4 Variables

The screenshot shows a blue background with white text. At the top, there is a box containing the word 'VARIABLES'. Below this, the following data is displayed:

	RED	WHITE	BLUE	
SUPPLY 1:	237	239	240	V
SUPPLY 2:	236	239	240	V
OUTPUT:	237	239	239	V
CURRENT:	20	20	20	A
kW	4.7	4.8	4.8	
kVA	4.8	4.9	4.9	
PF	0.98	0.98	0.98	
FREQUENCY 1	50.0 Hz	2 50.0 Hz		
SYNC	0 deg			

The Variables Menu shows the input and output variables including:

- Output Voltage
- Output Current
- Output Power Factor
- Output Power (kWatts)
- Output Power (kVA)
- Frequency for each source
- 1 Source Input Voltage
- 2 Source Input Voltage
- Phase Angle between Sources 1 & 2

Single phase units will display the Red column only.

## 5.5 Events List

DATE	EVENT	TARGET	
01.01.12	01:32:56	Supply2	OK
01.01.12	01:31:20	Supply2	FLT
01.01.12	01:31:19	Current	OK
01.01.12	01:31:19	Supply1	OK
01.01.12	01:20:56	S2 Average V	
01.01.12	01:20:56	S1 Average V	
01.01.12	01:18:34	Current	WRN
01.01.12	01:18:23	Alarm Cancel	
01.01.12	01:18:10	Heat Sink Temp	HI

The Events List shows 200 logged events that are recorded in real time. Once the buffer is full, the oldest events will fall from the buffer and get replaced by any new events. Refer to Event Codes section under Fault Diagnosis for an explanation of the codes.

## 5.6 Settings

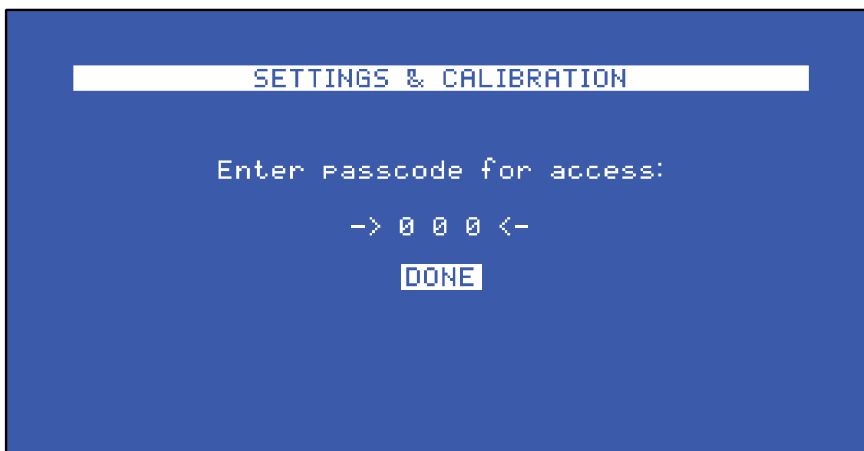

Use **▶** to move to the next digit and **▼** to change value.

Enter the passcode 0 – 0 – 0 to access Date & Time settings.

Enter the passcode 1 – 2 – 3 to access Settings.

SETTING	AUTO	MANUAL
SUPPLY 1 STEADY STATE HIGH	120	120
SUPPLY 1 STEADY STATE LOW	70	70
SUPPLY 2 TRANSIENT HIGH	120	120
SUPPLY 2 TRANSIENT LOW	70	70
STEADY STATE PAUSE		1.5
PHASE NORMAL	10	10
PHASE FAULT	30	
PHASE BREAK	50	
SUPPLY 1 TRANSIENT HIGH	130	130
SUPPLY 1 TRANSIENT LOW	65	65
SUPPLY 2 TRANSIENT HIGH	130	130
SUPPLY 2 TRANSIENT LOW	65	65
TRANSIENT PAUSE	2	
RETRANSFER TRIES	3	

SETTING	AUTO	MANUAL
SUPPLY 3 STEADY STATE HIGH	125	125
SUPPLY 3 STEADY STATE LOW	65	65
SUPPLY 3 TRANSIENT HIGH	133	133
SUPPLY 3 TRANSIENT LOW	60	60
CURRENT LOW	0	
CURRENT 110/125%	60	20
CURRENT 150/200%	10	1
TRANSFER TIMER	0	
FREQUENCY	10	10
PREFERRED	0	
MODE	S	S
PEAK CURRENT		0
FAN MODE	None	
USER IN.SSCODE	123	1

The Settings menu is where the user can adjust STS settings and calibrations, however it is recommended to adjust these settings the using the Web Browser Interface.

## 5.7 Date & Time

```

Configuration
SUNDAY 01.01.2012
TIME: 00:00:01
DONE

```

Entering the date and time should only be required once. We strongly encourage setting the correct time and date so that accurate real time event correlation can be undertaken. The real time clock is thereafter backed up by a battery cell.

## 5.8 Calibration

```
CALIBRATION                READ  ACTUAL
SUPPLY 1 VOLTS             255  256
SUPPLY 2 VOLTS             255  256
SUPPLY 3 VOLTS             255  256
SUPPLY 3 CURRENT           0    0
SUPPLY 3 KW                 4    4
PHASE                       0    0
R PHASE                    >>PHASE
```

For fine adjustment of volts and current of each phase.

## 5.9 Communication Settings

```
Communication Settings
IP Addr:  192 . 168 . 1   . 2
Subnet:   255 . 255 . 255 . 0
Gateway:  192 . 168 . 1   . 254
Use Defaults: Yes
Modbus Addr: 10
  DONE
```

The Communication Settings allows the user to set the network settings of the STS. The IP address allocation can be assigned automatically or set manually. We recommend using the Web Browser Interface to set IP settings.

## 5.10 Diagnostics

```
DIAG
SUPPLY 1 NOM OFFSET PEAK           -100
SUPPLY 1 NOM OFFSET STEADY STATE   -100
SUPPLY 2 NOM OFFSET PEAK           -100
SUPPLY 2 NOM OFFSET STEADY STATE   -100
SUPPLY 3 NOM OFFSET PEAK           -100
SUPPLY 3 NOM OFFSET STEADY STATE   -100

ON SUPPLY :                          2
S1 OK
S2 OK
```

The Diagnostic screen gives an analysis of each supply, including a list of how the STS is being affected.

## 5.11 Utilisation

```
UTILISATION
HOURS ON SUPPLY 1                   0
HOURS ON SUPPLY 2                   0
HOURS ON PREFERRED                   0
HOURS ACTIVE                         0
HOURS INACTIVE                      0

FORCED TRANSFERS:                   0
SYNC LOSSES:                        0
LOAD FAULTS:                        0
SUPPLY OUTAGES:                     0
LOAD FAULT:                          0
OUTAGE:
```

The Utilisation screen shows the total number of times certain events have occurred.

[A4]



## 6 Web Browser Interface

### 6.1 Connecting to a PC

When connecting directly to a PC, both the STS and PC must have statically assigned IP addresses on the same subnet. Set the IP address of the STS in the Communications screen described earlier. By default this is IP: 192.168.1.2 with Mask: 255.255.255.0

To set the IP address of your computer in Windows 7 go to: Network and Sharing Centre → Change adapter settings, right-click the network interface → Properties. Select TCP/IPv4→Properties. Change the values to match as shown below and click OK, you soon should be connected to your device.

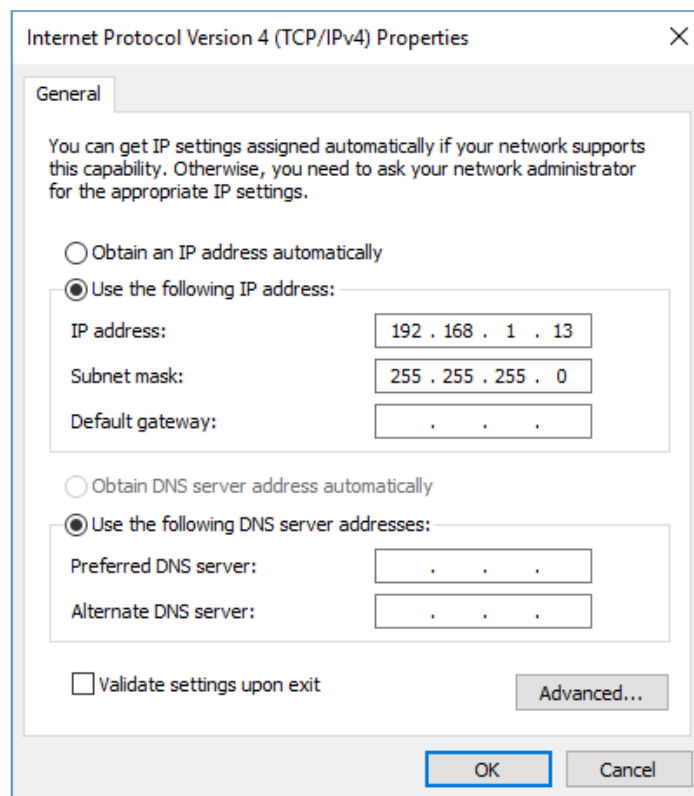

#### TCP/IPv4 Properties

For other operating systems, please refer to the OS networking manual.

## 6.2 Connecting to the Web Server

To use a ping test to confirm the connection on a PC, run command prompt (CMD) and type ping (space) then the IP address of the device then press enter.

Entering the IP address into the web browser address bar brings up the web server home page. If the DHCP / address have not yet been registered on your network you may need to remove the cable for 5 to 10 seconds and reconnect the cable, this in turn should re-register the device on the network.

**i-STS** NAME - LOCATION

**Supply 1 Online** **No Supply Preference**

**Variables**

	L1	L2	L3
Supply 1(V)	224	226	229
Supply 2(V)	226	224	229
<b>Output:</b>			
Voltage	226	197	227
Current(A)	24	22	25
Power(kVa x10)	56	45	57
Power(kW x10)	55	44	56
Power Factor	0.98	0.98	0.98

**Events**

Date	Time	Event	Target
16/04/2018	15:51:04	S3 Average V	OK
16/04/2018	15:51:04	S3 Average V	OK
16/04/2018	15:51:04	S3 Average V	OK
16/04/2018	15:51:04	Transfer	1
16/04/2018	15:50:59	S3 Average V	L3
16/04/2018	15:50:59	S3 Average V	L2
16/04/2018	15:50:59	S3 Average V	L1
16/04/2018	15:50:59	Initialise	

**Open Control Panel**

[L5]

### Web Server Home Page

The home page displays the connected supply, supply preference, variables and events list that can be scrolled through using the arrows provided. From the home page, gain access to the Control panel by clicking Open Control Panel and enter following username and password:

*Username: admin*

*Password: 1234*

## 6.3 Control Panel

On the Control Panel page, many more options become available:

- Viewing utilisation
- Ability to transfer supply
- Setting the preferred supply
- Setting the name and location information
- Adjusting the time and date
- Setting the IP address

**NOTE:** You must press update for the information to be saved on the device

The screenshot displays the Control Panel interface with the following sections:

- Control Panel Header:** Includes tabs for 'Control', 'Email', and 'Settings', and a close button (X).
- Utilisation:** A table showing various metrics:

Total Hours on Supply 1	0	Number of Synchronisation Losses	2
Total Hours on Supply 2	0	No of Load Fault	3
Total Hours on Preferred Supply	0	Last Load Fault	01/01/2012 00:00:00
Total Hours in Operation	0	No of Supply Outages	0
Number of Hours with no output	0	Last supply outage	13/02/2012 23:51:28
Number of Forced Transfers	3	Model Number	
- Supply:** Features a green 'Transfer Supply' button with a double-headed arrow.
- Set Preferred:** Includes buttons for '1', 'None', and '2', with 'None' currently selected.
- Eco Mode:** Includes buttons for 'ON' and 'OFF', with 'OFF' currently selected.
- Unit Details:** Contains input fields for 'Name' (with 'NAME' placeholder) and 'Location' (with 'LOC' placeholder), and an 'Update' button.
- Network:** Includes a DHCP toggle (set to 'Off'), IP address fields (192, 168, 1, 2), Mask fields (255, 255, 255, 0), and Gateway fields (192, 168, 1, 254), with an 'Update' button.
- Time & Date:** Includes time selection (0:10:00) and date selection (1/1/2012), with an 'Update' button.

[L6]

Control Panel screen

## **Transferring the Supply**

Clicking on the “Transfer Supply” will change to the alternate supply. If that supply is faulty the transfer will not occur.

### **Set Preferred**

The STS will stay connected to the preferred supply until there is a failure. In the case of the supply failing, the STS will switch to the alternate supply and then switch back to the preferred after the fault is cleared. When None is selected, the STS will not revert back to the other supply after switching.

### **Unit Details**

Enter a name for the device under “Name:” and the location it is stored at under “location:” this should be done so you can differentiate between different static transfer switches.

### **Date and Time Settings**

Enter the date and time, this should only be required once. We strongly encourage setting the correct time and date so that the real time event correlation can be undertaken. After pressing update the details will be stored into the unit. The real time clock is thereafter backed up by a battery cell.

### **IP Address Settings**

The default settings is set to DHCP mode “On”, when this is set to “Off” then the other options become available to change. From here you can change the IP, Mask and the Gateway. After pressing update these details will be saved on the unit.

## 6.4 Email

The Email tab allows you to turn on the email notification service. When a certain event occurs the unit will send an email to notify the user. The email takes the following format:

STS01 – LVL5

Supply 1 Fault - 05/05/2014 13:01:42

### Server Settings

This is the SMTP server that the unit will use to send the email. You need to provide the Server Address, Server Port, User name or email, and a password.

Note: this cannot be an SSL SMTP server.

### Recipient Email

This is where the email notification will be sent. It can be the same as the above email.

### Email List

In this section you can select which event types should trigger an email notification to be sent.

**Control** **Email** **Settings** ×

**Email Notifications**

ON  OFF Set

---

**Settings**

Server Address:

Server Port:

User name / Email:

Password:

Recipient Email:

Save

**Email List**

<input type="checkbox"/> Input/Output Faults	<input type="checkbox"/> Load/Current Warnings
<input type="checkbox"/> Frequency and Synchronisation	<input type="checkbox"/> Force/Override
<input type="checkbox"/> Preferred Supply Change	<input type="checkbox"/> User Transfers Warnings
<input type="checkbox"/> Bypass	<input type="checkbox"/> SCR/Thyristor
<input type="checkbox"/> Heat Warnings	<input type="checkbox"/> Power Supply Faults
<input type="checkbox"/> Transfer Inhibit	<input type="checkbox"/> Breaker Changes

Set

Email screen

## 6.5 Advanced Settings

Control Email Settings ×

### Input Steady State

	Auto	Manual
S1 steady state high value (%)	<input type="text" value="120"/>	<input type="text" value="120"/>
S1 steady state low value (%)	<input type="text" value="70"/>	<input type="text" value="70"/>
S2 steady state high value (%)	<input type="text" value="120"/>	<input type="text" value="120"/>
S2 steady state low value (%)	<input type="text" value="70"/>	<input type="text" value="70"/>
Steady state failure time (sec/10)		<input type="text" value="15"/>
Phase error detection normal (deg)	<input type="text" value="10"/>	<input type="text" value="10"/>
Phase error detection fault (deg)	<input type="text" value="30"/>	
Phase error detection break (ms)	<input type="text" value="50"/>	

### Input Transient

	Auto	Manual
S1 transient high value (%)	<input type="text" value="130"/>	<input type="text" value="130"/>
S1 transient low value (%)	<input type="text" value="65"/>	<input type="text" value="65"/>
S2 transient high value (%)	<input type="text" value="130"/>	<input type="text" value="130"/>
S2 transient low value (%)	<input type="text" value="65"/>	<input type="text" value="65"/>
Transient pause time (sec)		<input type="text" value="1"/>
Re-transfer timeout (sec)	<input type="text" value="5"/>	
Re-transfer max attempts	<input type="text" value="3"/>	

### Output

	Auto	Manual
Output steady state high value (%)	<input type="text" value="125"/>	<input type="text" value="125"/>
Output steady state low value (%)	<input type="text" value="65"/>	<input type="text" value="65"/>
Output transient high value (%)	<input type="text" value="133"/>	<input type="text" value="133"/>
Output transient low value (%)	<input type="text" value="60"/>	<input type="text" value="60"/>
Low current warning (%)		<input type="text" value="0"/>
High current time (minutes)	<input type="text" value="60"/>	<input type="text" value="20"/>
High current time (secs)	<input type="text" value="10"/>	<input type="text" value="1"/>
Transfer timer	<input type="text" value="0"/>	

### Settings screen

**NOTE:** The STS has been shipped with factory defaults. These are the most reliable settings for correct stable operation. These settings should only be changed under the certain operating conditions and it is advised that you consult with us before doing so, as wrong settings can make the system unstable and damage equipment.

## 6.6 Input Steady State Settings

These figures define the upper and lower limits of deviation from the nominal voltage and current of the input power that creates the fault condition to trigger the alarm and record the event.

### **S1 steady state high value (%)**

Default value of 120%, can be changed from a nominal value of 105 to 125. This number will be set as percentage.

Averaging time constant for this parameter is defined by Steady state failure time typically 1.5 seconds.

### **S1 steady state low value (%)**

Default value of 70%, can be changed from a nominal value of 0 to 95. This number will be set as percentage.

Averaging time constant for this parameter is defined by Steady state failure time typically 1.5 seconds.

### **S2 steady state high value (%)**

Default value of 120%, can be changed from a nominal value of 105 to 125. This number will be set as percentage.

Averaging time constant for this parameter is defined by Steady state failure time typically 1.5 seconds.

### **S2 steady state low value (%)**

Default value of 70%, can be changed from a nominal value of 0 to 95. This number will be set as percentage.

Averaging time constant for this parameter is defined by Steady state failure time typically 1.5 seconds.

### **Steady state failure time (sec/10)**

Default value of 15, this value will be divided by 10 making the value of 1.5 seconds.

This is the amount of time for the input power sources being outside of the limit values in order for the fault condition to be determined as true.

If this time is set to too small of a value it can cause erratic operation.

**NOTE:** By default the unit operates with the intelligent out of sync delay. To turn off the intelligent sync delay DIP SW2 must be turned on. The below phase settings should only be changed when intelligent sync delay is off.

### **Phase error detection normal (deg)**

This figure between 0 – 180 degrees, sets the maximum allowable separation between the two supplies, whereby if the supplies fall out of phase by this amount, the user will no longer be able to perform a manual transfer.

The default is 10 degrees.

Although the setting limit can be set from 0 to 180 degrees the consequence of transfer when asynchronous may result in a non-seamless transfer to the critical load. Ferromagnetic devices will saturate and draw large current when out of synchronism transfers are undertaken. The effect on some switch mode power supplies is also unknown. The user should consult with the equipment manufacturer to ensure that damage does not result from out of synchronisation transfers and what their recommended synchronisation limits are.<sup>[L7]</sup>

Setting to “0” disables the transfer pushbutton operation.

If the programmed value in the “Auto” column is exceeded no action takes place. Refer to “Phase error detection fault” below.

### **Phase error detection fault (deg)**

This is the degree of difference between phases of the supplies that will force a break time between automatically initiated transfers due to supply source / output supply faults. This can be set from 0 to 180 degrees. The recommended default is 30 degrees. Up until this value transfers that are initiated from the system (except manually) will occur without a break. Once the displacement between the two phases is more than this value, a break is inserted as defined by “Phase error detection break”.

### **Phase error detection break (ms)**

Setting this value to ‘0’ turns on the intelligent transfer delay mode where the device will automatically calculate a break time based on the degree of difference between the two supplies. For more information refer to ‘Prevention of Transformer Saturation’ technical report.

Otherwise this can be set from 10 – 150 msec with resolution of 10 msec. These are typical break insertion times; additional time would be added as a result of thyristor turn-off delays.<sup>[L8]</sup>

**NOTE:** In the scenario that two supplies are significantly out of synchronism, a break time will be insert to prevent inadvertent damage to equipment, tripping of protection devices or opening of fuses.



## 6.7 Input Transient Settings

These figures define the upper and lower limits of deviation from the nominal voltage and current of the input power that creates the fault condition to trigger the alarm and record the event.

### **S1 transient high value (%)**

Default value of 130%, can be changed from a nominal value of 108 to 135. This number will be set as percentage.

Transient time constant for this parameter is defined by “transient over-sampling time constant  $3 \times 312 \mu\text{sec}$ ”.

### **S1 transient low value (%)**

Default value of 65%, can be changed from a nominal value of 0 to 95. This number will be set as percentage.

Transient time constant for this parameter is defined by “transient over-sampling time constant  $3 \times 312 \mu\text{sec}$ ”.

### **S2 transient high value (%)**

Default value of 130%, can be changed from a nominal value of 108 to 135. This number will be set as percentage.

Transient time constant for this parameter is defined by “transient over-sampling time constant  $3 \times 312 \mu\text{sec}$ ”.

### **S2 transient low value (%)**

Default value of 65%, can be changed from a nominal value of 0 to 95. This number will be set as percentage.

Transient time constant for this parameter is defined by “transient over-sampling time constant  $3 \times 312 \mu\text{sec}$ ”.

### **Transient pause time (sec)**

This is the times that the values need to be outside the limit values before a fault condition is determined to be true.

### **Re-transfer timeout (sec)**

This parameter defines the delay before a re-transfer back to the original preferred source after the fault has been cleared and the source has returned to normal steady state conditions.

This parameter is usually set to 1 second. If this is set to a value too small, an unstable condition could arise from the source not having enough time to recover.

## **Re-transfer max attempts**

This setting refers to the number of times the device will transfer back to the preferred source. A lock out results after this but is re-set on a new fault alarm condition.

A setting of "0" inhibits retries and device will not transfer back to the preferred source.

**NOTE:** Adjustment may be required to the Transient values if the source supply voltages are distorted or above or below nominal. Setting too close a limit to the actual operating Steady State voltage may cause erratic Static Transfer Switch operation.

## 6.8 Output Settings

### Output steady state high value (%)

Default value of 125%, can be changed from a nominal value from 108 to 135. This number will be set as percentage.

Averaging time constant for this parameter is defined by “Steady state failure time” typically 1.5 seconds.

Set as a percentage from nominal – This parameter should always be wider than the S1 & S2 Steady state high threshold. This will ensure that when there is a problem with S1/S2 the event list will report correctly. S3 sensing is provided as redundant sensing for on line source S1 or S2 and in case of internal thyristor triggering fault.<sup>[E10]</sup>

When the output reaches this value the alarm will be triggered and the STS will transfer to the alternative source.

### Output steady state low value (%)

Default value of 65%, can be changed from a nominal value of 0 to 95. This number will be set as percentage.

Averaging time constant for this parameter is defined by “Steady state failure time” typically 1.5 seconds.

Set as a percentage from nominal – This parameter should always be wider than the S1 & S2 steady state low threshold. This will ensure that when there is a problem with S1/S2 event list will report correctly. S3 sensing is provided as redundant sensing for on line source S1 or S2 and in case of internal thyristor triggering fault. <sup>[E11]</sup>

When the output reaches this value the alarm will be triggered and the STS will transfer to the alternative source.

### Output transient high value (%)

Default value of 133%, can be changed from a nominal value of 108 to 135. This number will be set as percentage.

Transient time constant for this parameter is defined by “Transient over-sampling time constant 2 x 330 Micro Sec”.<sup>[E12]</sup>

Set as a percentage from nominal – This parameter should always be wider than the S1 & S2 transient high threshold. This will ensure that when there is a problem with S1 or S2 the event list will report correctly. S3 sensing is provided as redundant sensing for on line source S1 or S2 and in case of internal thyristor triggering fault. Operation is to transfer to the alternative source.

Transient limits should be set outside Steady state limits.

### **Output transient low value (%)**

Default value of 60%, can be changed from a nominal value of 0 to 95. This number will be set as percentage.

Transient time constant for this parameter is defined by “Transient over-sampling time constant 2 x 330 Micro Sec” Set as a percentage from nominal – Default setting 60% - This parameter should always be wider than the S1 & S2 transient high threshold. This will ensure that when there is a problem with S1 or S2 the event list will report correctly. S3 sensing is provided as redundant sensing for on line source S1 or S2 and in case of internal thyristor triggering fault. Operation is to transfer to the alternative source.

Transient limits should be set outside steady state limits.

### **Low current warning (%)**

Normally set to “0”, defines the minimum value for units load.

Setting to non-zero value will disable thyristor open circuit and short circuit detection until after the threshold has been reached.

### **High current time (minutes) at 110 & 125% Overload**

Exceeding the overload limits of 110% for greater than 60 minutes OR 125% for 20 Minutes will not affect the critical load and no switching occurs. It is intended as a warning that the STS is overloaded. Failure to reduce the load will cause semiconductor failures.

Consult manufacturer before setting to higher values to ensure that the unit will operate safely without failure or overheating.

### **High current time (secs) at 150 & 200% Overload**

Exceeding the overload limits of 150% for 10 Minutes OR 200% for 1 Minute will not affect the critical load and no switching occurs. It is intended as a warning that the STS is overloaded. Failure to reduce the load will cause semiconductor failures.

Consult manufacturer before setting to higher values to ensure that the unit will operate safely without failure or overheating.

### **Transfer timer**

Setting of “0” disables function.

After the set period the STS will undertake a test transfer to the alternate source. After a delay the load will be returned to the original source. This function is used to test functionality and protections within the STS.

# 7 Maintenance Bypass

## 7.1 Overview

Maintenance bypass mode allows the load to be connected to one supply without going through the power circuit of the STS. In this mode, transferring the load to an alternate supply is not possible. The maintenance bypass mode should only be used to select the presently operating source. It cannot be used to transfer the critical load from one source to the other.

The STS is put into maintenance bypass using the circuit breakers. The mechanical interlock panel is used to stop inadvertent operation of the circuit breakers and should never be removed or forced into an unnatural state.

If the Q1, Q2 or Q3 have been tripped and the toggle is in the centre tripped position, to reinstate the user must first depress the toggle to the off position before being able to raise the toggle into the on position. Similarly for Q4 and Q5.

**Do not defeat the mechanical and/or electrical interlock scheme of Q4 and Q5.**

**Do not operate the unit if the fans are not operating, Q1 & Q2 & Q3 must be open if fan fuses are removed.**

## 7.2 Using the OVERRIDE switch

In the case of a control failure the STS internal control logic can be overridden and the output can be forced to the correct state using the OVERRIDE switch to position 1 or 2 as appropriate. The switch needs to be in the centre "O" position for normal operation. The OVERRIDE switches provides control logic bypass only and it does not provide an alternative path for the load power.

**NEVER** attempt to operate the OVERRIDE switch if the supplies are not in synchronism. There is no interlock to prevent the switch from being operated when the supplies are not available or not in synchronism. Refer to the LCD variables display and mimic diagram for the not in synchronism state, (SYNC LED will be RED, variables display will show degrees out of synchronism. Only operate when less than 10 degrees). If the control is not operating you may need to use other means to determine that the supplies are in synchronism. Do not operate the OVERRIDE switch onto an absent supply.

## 7.3 Maintenance Bypass Procedure

### Bypass to Supply 1

1. Use the TRANSFER pushbutton to transfer the load to the desired source (Supply 1).
2. Move the OVERRIDE slide switch to position "1" corresponding to Supply 1, which should be presently supplying the load.
3. TURN OFF Q2, then move the interlocking bar so that the Q4 circuit breaker can be turned to the ON position. If Q4 has been tripped, you may need to reset the isolator to the OFF position before being able to turn ON.

4. Finally OPEN Q3 (The STS is now isolated from the output but the critical load is supplied from the Maintenance Bypass via Q4).

### **Bypass to Supply 2**

1. Use the TRANSFER pushbutton to transfer the load to the desired source (Supply 2).
2. Move the OVERRIDE slide switch to position “2” corresponding to Supply 2, which should be presently supplying the load.
3. TURN OFF Q1, then move the interlocking bar so that the Q5 circuit breaker can be turned to the ON position. If Q4 has been tripped, you may need to reset the isolator to the OFF position before being able to turn ON.
4. Finally OPEN Q3 (The STS is now isolated from the output but the critical load is supplied from the Maintenance Bypass via Q4).

### **THEN**

1. Before commencement of work on the STS it is necessary to open the incoming STS isolators Q1 and Q2. Note that dangerous voltages are still present within the STS.
2. To isolate the fans and electronics power, pulling out the knife fuses from the holder.
3. Do not operate the unit without the fans operating. e.g. Q1 & Q2 & Q3 must be open if fan fuses are removed.

## **7.4 Reinstatement from Maintenance Bypass Procedure**

1. Reinststate fuses for fans and electronic controls, if they have been removed.
2. Ensure that OVERRIDE slide switch is still switches to “1” if Q4 is ON or “2” if Q5 is ON.
3. Turn on circuit breakers Q1 and Q2 to energise power to all internal power connections.
4. Press and hold the ALARM pushbutton for at least 6 seconds to clear any operational inhibit condition. Note that the ALARM LED will still be illuminated as the STS is not in the normal condition.
5. Check the LCD display and mimic and ensure that the correct supply has been selected, remove the OVERRIDE by setting the slide switch to the centre (“0”) position. Again check the LCD display and mimic and ensure that the correct supply is indicated.
6. Turn Q3 ON. Again check the LCD display and mimic and ensure that the correct supply is still indicated.
7. Turn Q4 or Q5, (whichever is on) by pushing the toggle to the OFF position, both Q4 and Q5 should now be open.
8. The load is now supported by the STS.

9. Use the TRANSFER pushbutton on the front control panel to select the desired source. Check and ensure that this corresponds to the PREFERRED source selection, (located above the OVERRIDE switch).
10. Check that the LCD display and mimic correctly reflect the state of the system and that the ALARM LED is off.

# 8 Fault Diagnosis

## 8.1 Fault Codes

Event Descriptor	Append	Description	STS Action Resulting
INITIALIZE		RAM CHKsum failed – Cold Start (RAM Corrupt) – Flash Defaults downloaded	None - Contact Static Power
WARM BOOT		Power-up, Warm Start, re-initialize all but RAM – Keeps Event List	Normal After Black Start
WATCHDOG TIMER	Diagnostic	Signals software / hardware problems	None - Contact Static Power
STACK	Diagnostic	Stack or Heap has overflowed	None - Contact Static Power
EEPROM		FLASH/ EEPROM Checksum error – cal may be damaged	None - Contact Static Power
ROM		FLASH ROM has been corrupted (Program is in error)	None - Contact Static Power
BATTERY		Battery has low power (needs replacing)	None - Contact Static Power
COMMS	1/2/3/4/5/6/7/8	Communications has failed to Dig Proc, Ana1, Ana2.	None - Contact Static Power
CALIBRATION	1/2/3	Calibration of MSP required	Contact Static Power
LOW POWER MODE	ON/ OFF	LOW POWER MODE (Power Down Modes @ loss of electronics power)	LOW POWER MODES
S 1 / S2 / S3	AVERAGE V (R,W,B)	Supply 1 or 2 OR 3 has Steady State High or Low or phase R, W or B	Transfers to supply 2 if on 1
S 1 / S2 / S3	TRANS V (Red, White, Blu)	Supply 1 or 2 OR 3 has Transient High or Low (1 sec)	Transfers to supply 2 if on 1
S 1 / S2 / S3	LOW /OK	Supply 1 or 2 OR 3 has Steady State Low (1 sec)	Transfers to supply 2 if on 1
S 1 / S2 / S3	HI / OK	Supply 1 or 2 OR 3 has Steady State High (1 sec)	Transfers to supply 2 if on 1
SUPPLY 1 or 2 or 3	FAILED / OK	Supply 1 or 2 OR 3 has Steady State High (1 sec)	Transfers to supply 2 if on 1
OVERRIDE	0,1, 2	Controls Override set to S1	User - Manual Switch Only
PREFERRED	0,1, 2	Preferred Source Set (0 or 1)	User - Manual Switch Only
S 1 / S2	FREQ LOW / HI /OK	Frequency of supply 2 is high or low	Alarm No action



<b>Event Descriptor</b>	<b>Append</b>	<b>Description</b>	<b>STS Action Resulting</b>
LOCAL XFER	1, 2	Local Transfer to Supply 1 or 2 requested	User - Manual Action
REMOTE XFER	1, 2	Remote transfer to Supply 1 or 2 requested	Via User Inputs or BMS
BACK FEED	1 or 2 on (R, W, B)	Back feed voltage too high on S1 or S2	Contact Static Power
REMOTE POWER	OFF/ON	Remote Supply off Requested (EPO)	Via User Inputs or BMS
SYNCHRONISATION	LOS / OK	S1 & S2 not in synchronism	Alarm No action
CURRENT	WARN / HIGH /FAULT/OK	Output is overloaded (timed shutdown)	Alarm No action starts timer
HEAT SINK TEMP	HI /OK	Fans Failed or Over Stressed Device Temperatures, Heat Sink is Over temperature	No Action – Check & Reduce Loading or Ambient
LOAD FAULT	FLT/ CLR	There was a fault at the load	Does not transfer (Inhibit)
FAN	FAIL / OK	Status Indication Only	No Action - Repair
THDI	HI / OK	Total harmonic Distortion of current is very high	Alarm No Action – Check Load
THDV	HI / OK	Total harmonic Distortion of Voltage is too high	Alarm No action - Check Load
BREAKER OPEN	Q1, Q2, Q3, Q4 or Q5	Status Indication Only	Response to interlocking controls
BREAKER CLOSED	Q1, Q2, Q3, Q4 or Q5	Status Indication Only	Response to interlocking controls
TRIPPED	Q1, Q2, Q3, Q4 or Q5	Status Indication Only	Response to interlocking controls
ALARM CANCEL		Alarm Cancel was pressed	Resets Audible & Latched fault
POWER SUPPLY	1,2 or 3	Status Indication Only	None -Contact Static Power / Repair
SCR SC	S1,S2 R, W, B, N	SCR on S1 or S2 short circuit detected on phase #	Contact Static Power – Locks to safe source
SCR OC	S1,S2 R, W, B, N	SCR on S1 or S2 Open circuit detected on phase #	Contact Static Power – Locks to safe source

## 8.2 Load Fault

In case of sustained high current output load faults, the STS will inhibit a transfer to the alternate supply even if this means degradation or loss of source supply. It is therefore imperative that you ensure that the discrimination with downstream and upstream protective devices ensures that the downstream protective device always clears the fault first.

In case that all output is lost the faulty equipment should be located and removed from the STS output before re-instatement of power.

We recommended putting the source(s) (1 or 2) into bypass to allow greater capacity to isolate downstream faults without affecting UPS output voltage integrity. It will be necessary to gain access to the circuit breakers of the STS and follow the Maintenance Bypass Procedure.

This should clear any downstream faults still present, then reinstate the power from Maintenance Bypass and hold the alarm pushbutton for 10 seconds to clear/acknowledge alarms.

If the STS is inoperable or if the fault does not clear then it should be returned to the manufacturer for repair or replacement.

## 9 Maintenance

### Recommended Schedule

- Once per month record the operating variables and compare with the specifications and operating parameters to ensure that the unit is operating correctly.
- Check the Event History and correlate any recorded events since last observation with real occurrences. Report / investigate any suspicious entries.
- Once every 6 months, (sooner if the environment is bad), vacuum dust from grills at front of unit.
- Inspect cable / plug connections for overheating.
- Units with fans need their fans changed every 3-5 years. This may need to be sooner if the environment is bad.

Please contact Static Power for help with troubleshooting and parts replacement.

# 10 Specifications

<b>Power</b>			
Type	1-phase / 2-pole	3-phase / 3-pole*	3-phase / 4-pole*
Current rating	63A to 160A		
Voltage rating	All region-specific voltages selectable $\pm 10\%$		
Safe install environment	20kA for 1 cycle, fuse-less design		
Frequency	50Hz and 60 Hz, $\pm 10\%$ Auto detection		
Max THDV	15 % (max allowable source voltage distortion)		
Power factor	No practical limit		
Crest factor	3.5 : 1		
Loading	0 – 100% @45°C ambient		
Overload capacity	500A for 30s 1kA for 1s 20kA for 1 cycle		
Input / Output	Fixed wiring to M10 lugs to terminals for up to 95mm <sup>2</sup> cables via gland plate		
Maintenance bypass	5 mechanically interlocked circuit breakers		
Isolation	Incoming source isolation switches, front mounted behind door		
<b>Switching</b>			
Transfer type	Transfer at zero current by break-before-make by Thyristors / SCR		
Detection	Digital: <1ms		
Break time	<1ms to <¼ cycle		
Asynchronous break time	Settable from 0ms to 150ms or Vt proportional		
dV/dt max	800V/ $\mu$ s		
MTBF	800,000 hours @ 25°C ambient – Recommend Routine Preventative Maintenance @200,000h		
Device ratings	600A RMS, 1800V, 2kA, 1 cycle		
Fault current setting	>350% peak with load fault transfer inhibit		
Protection	Circuit breakers		
<b>Communication &amp; control</b>			
User interface	Bi-colour LED mimic decal with graphic OLED display Preferred supply selection, source transfer selection Controls override & transfer inhibit switches Alarm cancellation pushbutton		
Contacts	In: 2 Self wetting transfer control inputs and Emergency fire stop Out: 5 Voltage free change-over status indicators, Form C		
Ethernet	HTTP - web user interface or reporting & control SNMP - 120 unique reports & transfer control Modbus TCP/IP - 120 unique reports & transfer control Email alerts Clock synchronisation with NTP		
<b>Environmental</b>			
Dimensions (H W D)	800 x 600 x 400mm		
Weight	60 – 97 kg (typically)		
Temperature	0 – 45 °C		
Cooling	Redundant fans		
Humidity	5 – 95 % non-condensing		
IP rating	IP20		
<b>Compliance</b>			
Regulatory	IEC 62310-1,2,3 - IEC 60950 - IEC 61000-6-1,2,3,4 – CE – RCM - RoHS - UL Capable		
Standard warranty	24 months off site repair or replacement policy		

\* 3-phase 3 and 4-pole models are 4-wire + earth unless otherwise stated.

# 11 Operating Parameters

## Absolute Maximum Values

Parameter	Min	Max
Input Voltage (N-L)	200V	265V
Load Current	-	160A
Input Synchronisation	-180°	180°
Ambient Temperature	-20°C	45°

## Recommended Values

Parameter	Min	Max
Input Voltage	210V	255V
Load Current	0	160A
Input Synchronisation	-15°	15°
Ambient Temperature	0°	30°

## Overload Capacity

Load	Time
500 A	30 s
1 kA	1 s
20 kA	20 ms

## 12 Contact Information

The information contained in this user manual may be superseded at any time.

For the latest information check the website at: <http://www.staticpower.com.au/>

This document is property and copyright of Static Power Pty. Ltd.

---



iSTS Manufacturing is a subsidiary of

STATIC POWER PTY. LTD.

ABN 42 101 765 913

### Contact Us

---

Phone	+613 9437 0494
Email	<a href="mailto:support@i-sts.com.au">support@i-sts.com.au</a>
Web	<a href="http://www.i-sts.com.au">www.i-sts.com.au</a>

### Place of Manufacture

---

Static Power  
5 Candlebark Court  
Research VIC 3095  
Australia

### Post to

---

Box 2003  
Research Delivery Centre  
Research VIC 3095  
Australia