

iSTS

Model B2

User Manual

19-inch Rack Mount Static Transfer Switch



STATIC POWER Pty Ltd
ABN 42 101 765 913
iSTS B2 – User Manual

Post to:
Box 2003
Research Delivery centre
Research, VIC 3095 - Australia

Manufactured at:
5 Candlebark Court
Research, VIC 3095
Australia

Contact us:
+61 3 9437 0494
support@staticpower.com.au
www.staticpower.com.au

CONTENTS

1. SAFETY INSTRUCTIONS	2
1.1 Introduction	2
1.2 Transport, Storage, Unpacking	2
1.3 Installation	2
1.4 Maintenance Bypass	3
1.5 Fire Regulations	3
1.6 Standards Applied & Conformity	3
1.7 Warranty	3
2. SYSTEM OVERVIEW & OPERATION	4
2.1 Description	4
2.2 Overview	4
2.3 Operational Parameters	5
2.4 Line Diagram: Single Phase/2-Pole	5
2.5 Line Diagram: 3 Phases, Neutral available and not switched	6
2.6 Line Diagram: 3 Phases, Neutral switched	6
3. OPERATION	7
3.1 Safety	7
3.2 Installation	8
3.3 Terminating Cables to the iSTS	8
3.4 Synchronism	9
3.5 Start-up	9
4. USER INTERFACE	10
4.1 Mimic	10
4.2 Display Screen	11
4.3 Preferred Switch	13
4.4 Override Switch	13
4.5 Remote Connection Port – High Density DA-26	14
4.6 Confirm Operation	15
5. MAINTENANCE BYPASS	15
5.1 Overview	15
5.2 Maintenance Bypass Procedure	15
5.3 Reinstatement from Maintenance Bypass	16
6. WEB BROWSER INTERFACE	16
6.1 Connection to a Network	16
6.2 Connecting to a PC	17
6.3 Connecting to the Web Server	17
6.4 Control Panel	18
6.5 Email	20
6.6 Advanced Settings	21
6.7 Input Steady State Settings	22
6.8 Input Transient Settings	23
6.9 Output Settings	24
7. FAULT DIAGNOSIS	25
7.1 Fault Codes	25
7.2 Load Fault	25
8. RECOMMENDED MAINTENANCE SCHEDULE	26
9. SPECIFICATIONS	27

1. SAFETY INSTRUCTIONS

1.1 Introduction

Some aspects of this manual's contents may differ to the equipment as supplied due to technical improvements, specific model variations etc. If in any doubt in respect to the procedures and safety issues consult the manufacturer and do not proceed until clarification is received.

This manual contains important instructions that should be followed and fully understood before proceeding and commissioning and operation to prevent harm to personnel and equipment.

Installation and commissioning should be carried out only by qualified and experienced electricians. The iSTS should be operated by technically qualified personnel that are authorized, experienced and have knowledge and understanding of the equipment and the critical loads, using the documented procedures.

Read this whole document thoroughly. Understand every aspect before proceeding. Request further assistance if you do not understand any aspect of the operation of the iSTS. Support and contact numbers are at the end of the manual.

These instructions cover normal operation in the automatic as well as in manual modes. Special operating conditions, such as short circuit tests, input supplies, etc., are not covered in this document. These operations require comprehensive knowledge of the overall system and should be carried out by properly qualified, skilled and competent service personnel only.

1.2 Transport, Storage, Unpacking

Procedure for Receiving Shipment:

- If the ShockWatch indicator is RED, it does not mean that damage has occurred, it only indicates that the carton received an impact or movement. If the indicator on the label is RED, make a notation to that effect on the bill of lading or delivery receipt or document. Examine contents immediately for possible damage. If damage is discovered, inform carrier immediately and follow normal procedure for a carrier inspection and filing of a concealed damage claim
- If the packaging is damaged unpack carefully and inspect the unit. We recommend that if there is any sign of mechanical damage that the unit not be powered up; but, returned for re-processing
- If damage is discovered, inform carrier immediately and follow normal procedure for a carrier inspection and filing of a concealed damage claim to the courier or your insurance company.
- Take a picture of the carton and contents as a record.
- If the packaging is OK, then please keep the packaging in a secure place in case the unit needs to be returned for repair.

1.3 Installation

The following instructions are provided for the personal safety of operators and also for the protection of the described product and connected equipment.

- Observe the prescribed accident prevention and safety rules for the specific application.
- When installing the iSTS strictly observe all information on technical data and operating conditions. Comply with all warnings, and strictly follow the procedures and practices as described in this manual.
- This iSTS is intended to be used in a controlled indoor environment and free of conductive contaminants and protected against animal intrusion.
- It is important that the unit has adequate ventilation. Maintain air movement around and through the unit. Do not block the air vents or restrict airflow over the heatsinks.
- The unit must be placed in a sufficiently ventilated area; the ambient temperature should not exceed 40°C (104°F).
- Do not install the iSTS in an excessively humid environment or near water, relative humidity should not exceed 90% at 20°C (68°F).
- Avoid spilling liquids or dropping any foreign object into the iSTS.
- Once the connections have been made on the terminals, all terminal covers must be replaced before operation.
- Connecting cables must be supported.
- Earth connection must be checked for safe function after assembly.

1.4 Maintenance Bypass

WARNING:

REFER TO THE MAINTENANCE BYPASS SECTION BEFORE ATTEMPTING TO PUT THE UNIT INTO MAINTENANCE BYPASS MODE.

THE MAINTENANCE BYPASS SWITCH UTILISES MAKE-BEFORE-BREAK SWITCHING, INCORRECT OPERATION OF THE MAINTENANCE BYPASS FEATURES COULD RESULT IN DANGEROUS VOLTAGES OCCURRING AND SHORT CIRCUITS.

1.5 Fire Regulations

Should a fire break out inside the system a fire extinguisher with CO² or similar non-conductive, non-corrosive and inert gas must be used. Do not inhale vapours.

1.6 Standards Applied & Conformity

The iSTS B2 conforms to the following standards and European Council Directives:

Standards to which conformity declared:

- IEC 60950-1 Information technology equipment Safety - General requirements
- IEC 62310-1 Static transfer systems (STS) - General and safety requirements
- IEC 62310-2 Static transfer systems (STS) - Electromagnetic compatibility (EMC) requirements
- IEC 62310-3 Static transfer systems (STS) - Part 3: Method for specifying performance and test requirements

Application of Council Directives:

- 2006/95/EC Low Voltage Directive
- 1992/31/EEC EMC Directive
- 1993/68/EEC EMC Directive amendments
- 2011/65/EU Hazardous substances in electrical and electronic equipment - RoHS

Year of CE marking: 2015-2016



The Standards mentioned above fulfil the requirements for CE marking

1.7 Warranty

Static Power operating through its authorised agents warrants that the standard products will be free of defects in materials and workmanship for a period of 24 months after the date of invoice, or such other period as may be specified.

This warranty does not cover failures of the product which result from incorrect installation, misuse, alterations by persons other than authorized agents or abnormal operating conditions.

More about warranty: staticpower.com.au/wp-content/uploads/2019/11/Warranty-Statement.pdf

iSTS B2

2. SYSTEM OVERVIEW & OPERATION

2.1 Description

A Static Transfer Switch (STS) provides seamless switching between two power sources to provide uninterrupted power to a critical load.

The iSTS continuously monitors the supply sources for failure or degeneration and switches automatically to the alternate source as required to protect the load against failure. The break in the supply transition is so short that it is not seen by the critical load. This switching process is undertaken as a break before make transfer, preventing overlapping which can cause large and unpredictable currents. In 2 and 4-pole models, all the active conductors and the neutral are switched. In 3-pole models, only the active phases are switched. Thyristors are used to undertake the switching process.

In the case of downstream load fault conditions, the fault current drawn from the supply may degrade or damage the supply sources; as a consequence should a fault current exist in the load the iSTS will inhibit a transfer to the alternate source even if this causes source supply degradation or loss. This is to ensure that the fault will not be transferred to the alternate supply with the possibility of degrading both sources.

The current threshold for isolation is pre-set to approx. 300% of the rated current.

This unit contains fuses. The fuses are to provide for safe operation even in high fault capacity environments. It should be noted that the fuses are for the protection of the semiconductor switches (SCRs/ Thyristors), not the load. The iSTS does not have any automatic tripping devices, so load discrimination is undertaken in the primary and secondary supply networks.

2.2 Overview

The iSTS comprises a hot socket removable/replaceable power module. Replacement is achieved in conjunction with the Maintenance Bypass Switch located at the front of the iSTS.

NOTE: The model pictured is 4-pole STS. 2 and 3-pole models differ.



2.3 Operational Parameters

Absolute Maximum Values	Min	Max
Input Voltage	100VAC	300VAC/530VAC
Load Current	-	16A to 125A
Input Synchronisation	-180°	+180°
Ambient Temperature	0°C	45°C

Recommended Values	Min	Max
Input Voltage	210VAC	277VAC/480VAC
Load Current	0A*	16A to 125A
Input Synchronisation	-15°	+15°
Ambient Temperature	0°C	30°C

*Due to the nature of the silicone controlled rectifiers used in all static transfer switches, some current must be applied to the iSTS to ensure a clean break during transfers.

Overload Capacity @20°C	Time
100A	30s
250A	1s
400A	0.1s
2000A	1 cycle

2.4 Line Diagram: Single Phase/2-Pole

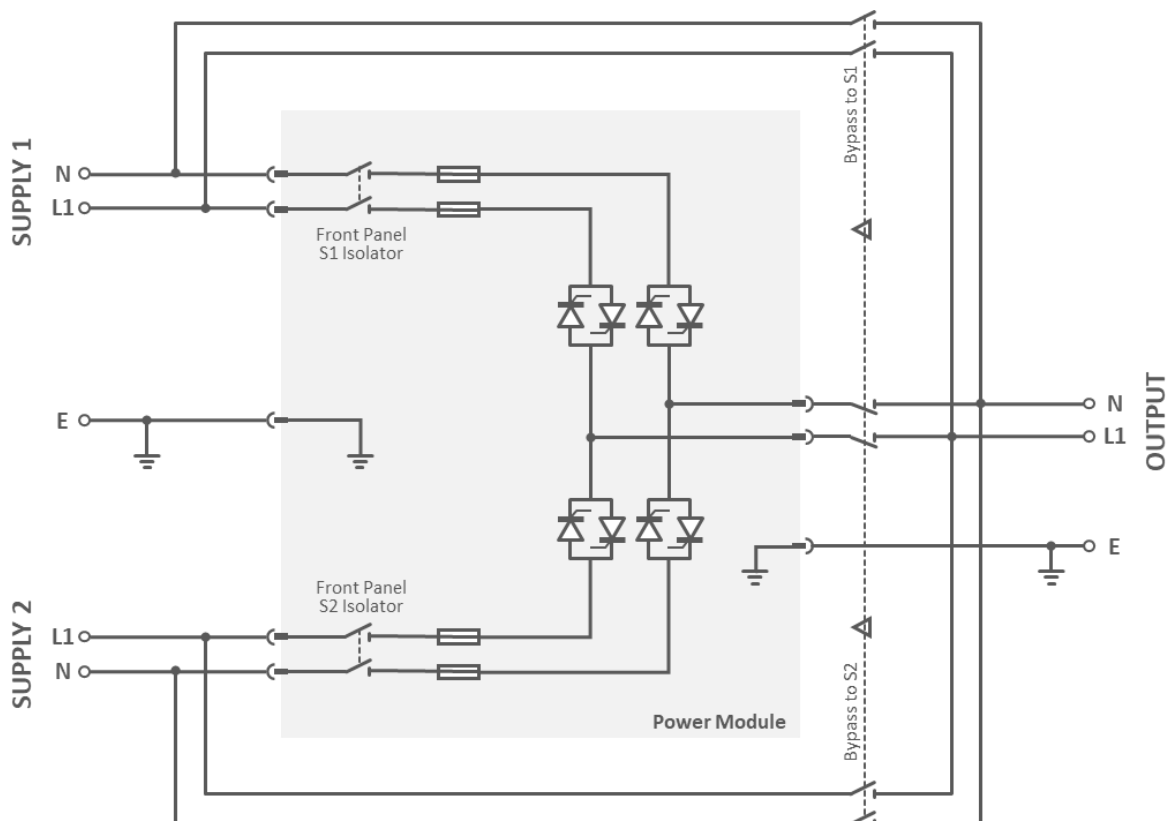

2.5 Line Diagram: 3 Phases, Neutral available and not switched

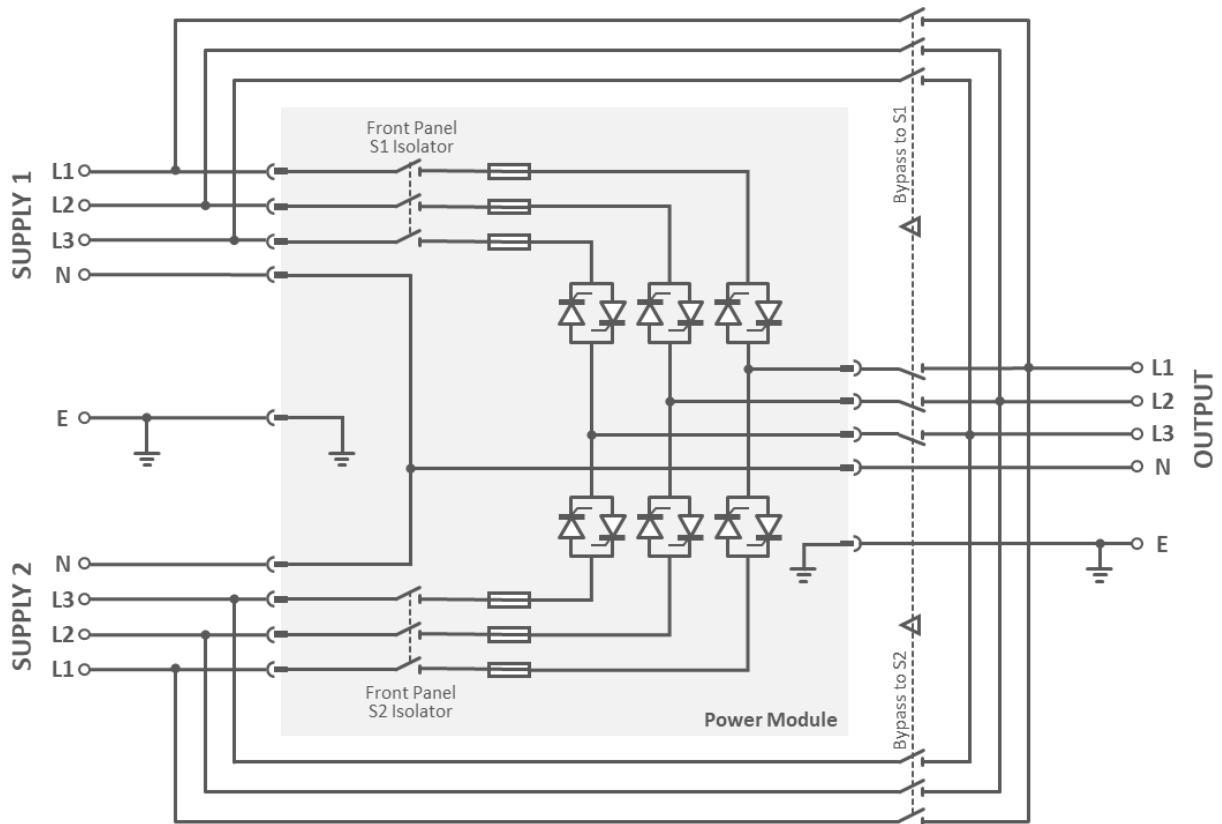

2.6 Line Diagram: 3 Phases, Neutral switched

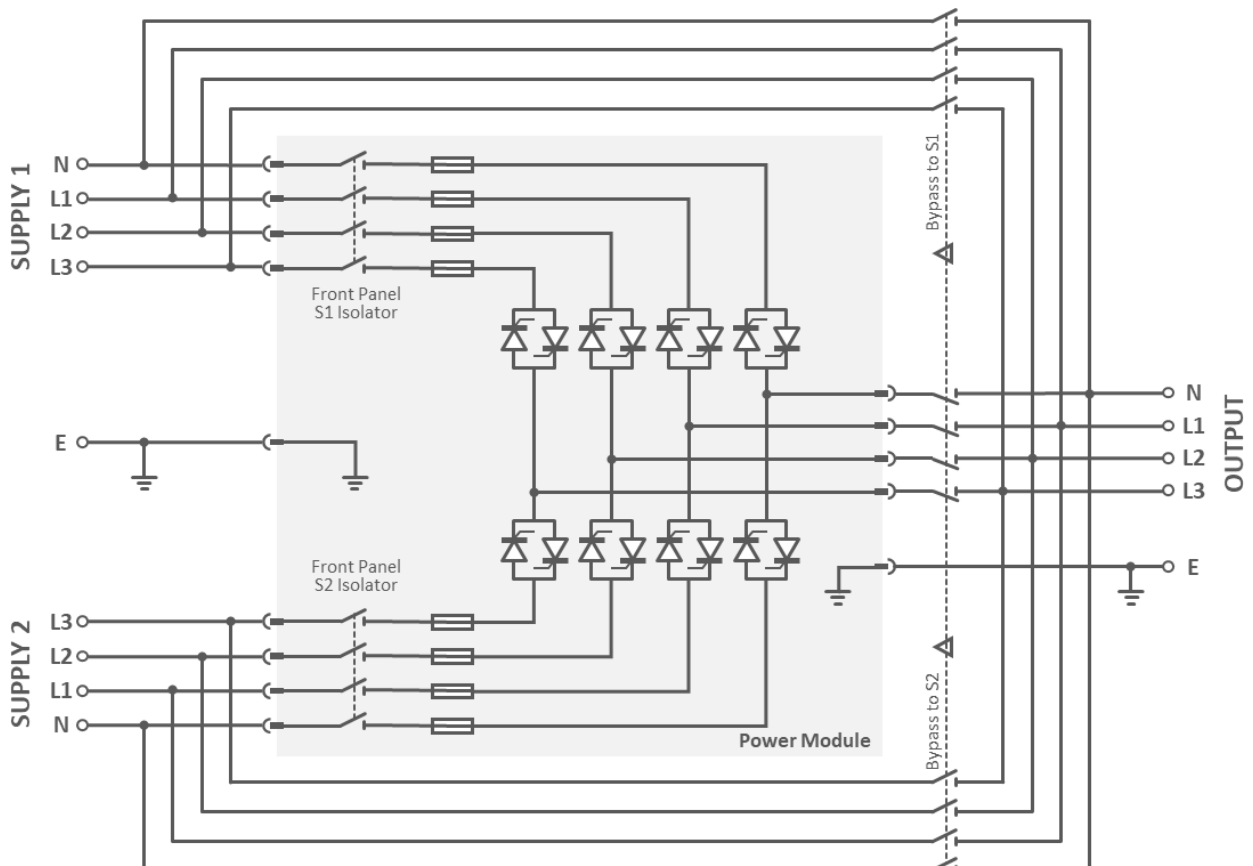

3. OPERATION

3.1 Safety

The iSTS is powered from two separate sources. It is important that you install correct signage with procedures within the enclosure and the immediate vicinity to warn personnel of this aspect and what isolation, checking and precautionary processes, and procedures need to be adopted to make the iSTS and equipment connected to the iSTS safe to work on.

This equipment receives power from more than one source. Disconnect output and all input sources of power from this equipment before servicing.

Do not proceed with the installation or operation of the iSTS if it has been damaged. Carefully inspect the iSTS for any damage that may have occurred during shipping, unpacking or during and after any installation process.

Take care when handling the iSTS and ensure that it is physically supported during the installation process. At the end of the installation process the iSTS should be firmly and securely bolted within the rack.

Ensure the cables are securely connected and supported and all covers plates are replaced. There should be **NO** live exposed or accessible contacts that could cause electrical shock if contact is able to be made. This unit is designed for fixed wiring installation only.

This equipment is not suitable for installation into environments that utilise RCD earth leakage detectors on the inputs of the static transfer switch. Consult Static Power for special considerations.

**EARTH CONNECTION IS ESSENTIAL BEFORE WORKING ON CIRCUITS
OR CONNECTING / DISCONNECTING SUPPLIES.**

TREAT AC INCOMING LEADS AS LIVE IF DISCONNECTING FROM SOURCE.

3.2 Installation

1. Secure the iSTS into your rack by the four holes on the front of the cradle portion.
2. Ensure that the power module portion of the STS is securely mated with the cradle.

3.3 Cable Termination to the iSTS

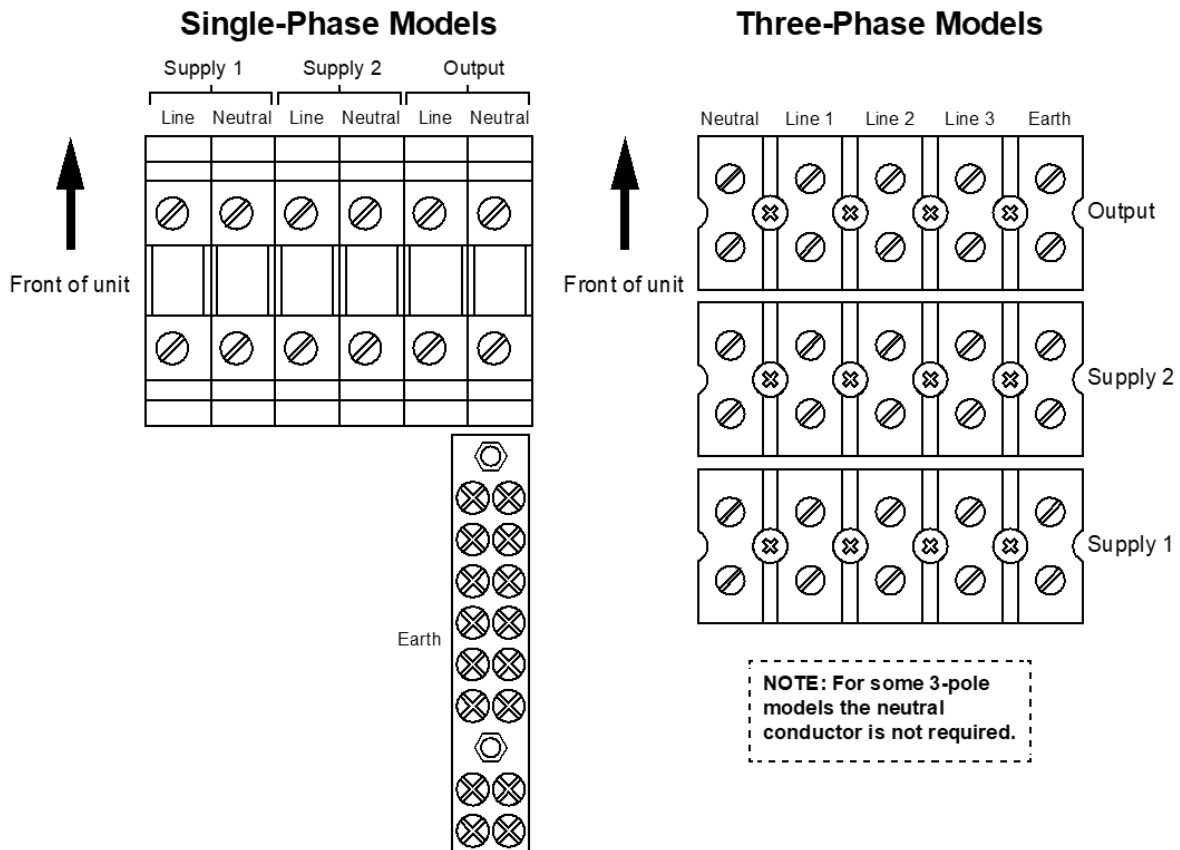

1. With all power removed, mount the cradle only into the rack. Remove screws on the panel on the cradle to gain access to the terminals.
2. To access the input and output terminals at the rear of the cradle, remove the 2 screws on each of the gland plates and then remove the plate.
3. Cable size is limited to 16mm² for units up to 63A and 35mm² for 125A single phase iSTS B2.
4. Connect Active, Neutral and Earth cables to the respective spring cage terminals as marked on the board. Secure the connections on the terminal blocks, torque the screw to 25Nm / 20in-lbs. All cables connecting to the STS should be supported and not weigh the rear of the iSTS or strain the point of connection.
5. All electrical connections are to be realized by properly qualified, skilled and competent service personnel only.
6. Insert the power module into the cradle and ensure that the module is pushed completely to the front.
7. Before applying power to the iSTS, make sure that the rated voltage for the unit corresponds to the ratings plate and the local supply voltage.

When working on live iSTS, be sure to comply with the applicable national accident prevention rules.

3.4 Synchronism

The smoothest change-over occurs when the supplies are in synchronism, so it is best to make sure the input supplies are in synchronism. Some equipment (like transformers) may saturate when a transfer occurs when not in synchronism. This causes large currents to flow into the load which could cause damage to the transformer, trip protective devices or blow fuses.

The iSTS is configured to optimize the transfers. Manual transfers by default have uninterrupted transfers, however, at greater phase displacements (up to ± 180 degrees) a break of up to 12ms is inserted.

3.5 Start-up

NOTE: Due to the nature of SCRs (silicon controlled rectifiers) some load of around 0.5A is required for correct operation. Before testing the operation of this iSTS, make sure this load is applied to the output.

1. Ensure that your two input sources are within the tolerances and in synchronism..
2. Apply power to both input sources. There will be a short 15 second start-up period, after which the iSTS will begin powering your load.
3. you will be prompted to enter the date and time. We strongly encourage the setting of the date and time so that real time event correlation can be undertaken. The Real Time Clock is backed up by a rechargeable coin cell battery. If the battery is flat at the time of commissioning it may take several days to re-charge.
4. The ALARM should not be active. If it is check the following conditions that may be active:
 - ON Supply 1 when priority is Supply 2
 - ON Supply 2 when priority is Supply 1
 - Supply 1 or Supply 2 are not in spec
 - Override Switch is in position 1 or 2
 - Supply 1 & 2 are not in synchronism
 - The unit is too hot (thermal bi-metal switch on H.S. activated)
 - There is / was an overcurrent/ overload / load fault condition

4. USER INTERFACE

4.1 Mimic

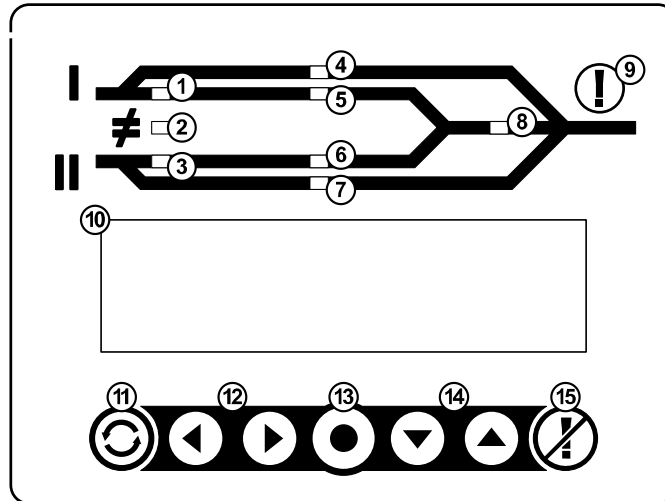

Name	GREEN	RED	Normal State
1 SUPPLY 1 OK LED	Supply 1 is within tolerance	Supply 1 is out of tolerance	GREEN if Supply 1 is ON
2 SYNC OK LED	Supply 1 and Supply 2 are within synchronisation range to perform a transparent transfer	Supply 1 and Supply 2 are not within synchronisation range to perform a transparent transfer	GREEN when Supply 1 and Supply 2 are both ON
3 SUPPLY 2 OK LED	Supply 2 is within tolerance	Supply 2 is out of tolerance	GREEN if Supply 2 is ON
4 SUPPLY 1 BYPASS LED	iSTS is bypassed to Supply 1	No RED LED	OFF unless Supply 1 bypass is active
5 ON SUPPLY 1 LED	Load is on Supply 1	Load is not on Supply 1	GREEN if load is Supply 1
6 ON SUPPLY 2 LED	Load is on Supply 2	Load is not on Supply 2	GREEN if load is Supply 2
7 SUPPLY 2 BYPASS LED	iSTS is bypassed to Supply 2	No RED LED	OFF unless Supply 2 bypass is active
8 iSTS OUTPUT LED	Output is OK	Output is faulty	GREEN

Name	Description
9 ALARM LED	RED light and audible alarm indicates a fault. Pressing the Alarm Cancel button will silence the alarm and the light will stay on until the fault is cleared. The fault will be recorded in the Events List
10 LCD DISPLAY	Shows Supply Status, Alarms, Settings, Events List and Settings
11 PREFERRED SUPPLY BUTTON	Press to cycle the preferred source as 1, 2 or none. The iSTS will default to the preferred supply when it becomes available
12 LEFT/RIGHT NAVIGATION BUTTONS	Use to scroll through menu items and enter input fields
13 ENTER BUTTON	Enter/OK button
14 UP/DOWN NAVIGATION BUTTONS	Use to scroll through menu items and enter input fields
15 ALARM CANCEL BUTTON	When a fault occurs, press to acknowledge alarm and turn off the audible alarm while. The Alarm LED will remain on until the fault is cleared
13 & 15 ALARM MUTE	Pressing the two buttons together will mute the audible alarm. The visual alarm will not be affected

4.2 Display Screen

HOME SCREEN

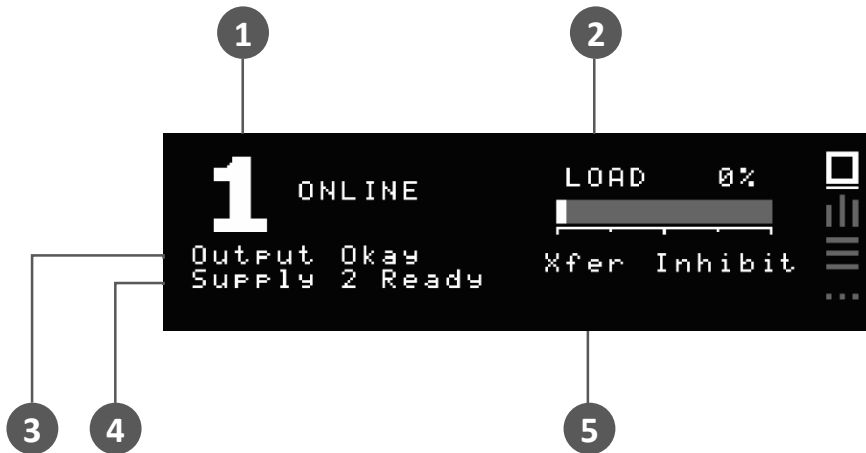

Name	Description
1 Preferred Supply Status	Shows the preferred supply and the status of the source connected to the load
2 Load Indicator	Bar and percentage represent the current capacity of the STS that is being used
3 Output Status	Indicates the status of the output
4 Inactive Supply Status	Indicates the status of the supply that is not connected to the load
5 Priority Alarm	The message displayed will be the most important alarm (refer to Event Codes in the Fault Diagnosis section)

VARIABLE SCREEN

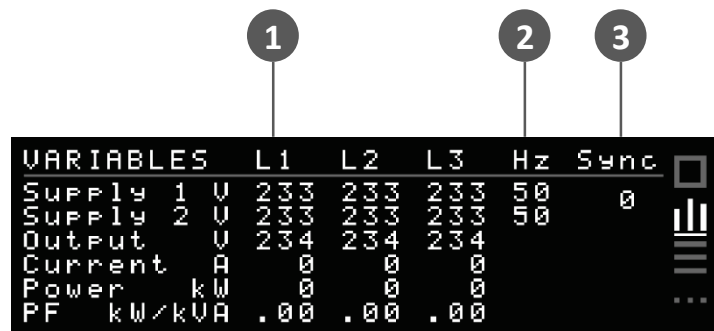

Name	Description
1 Line Stats	Lists the Voltage, Current, Power and Power Factor for Supply 1, Supply 2 and Output across each phase line (Single phase units will only show L1)
2 Frequency	Shows the frequency of the input supplies
3 Sync	This is the difference between the frequencies of Supply 1 and 2 in degrees

EVENTS SCREEN

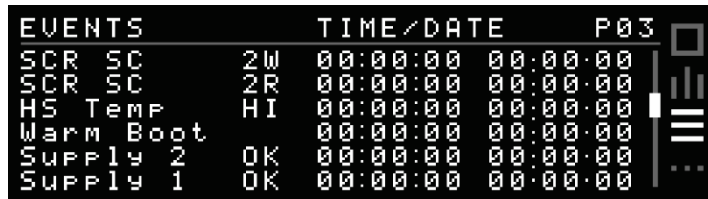

EVENTS		TIME/DATE	P03
SCR SC	2W	00:00:00	00:00:00
SCR SC	2R	00:00:00	00:00:00
HS Temp	HI	00:00:00	00:00:00
Warm Boot		00:00:00	00:00:00
SUPPLY 2	OK	00:00:00	00:00:00
SUPPLY 1	OK	00:00:00	00:00:00

Use Up and Down to scroll through 200 logged events. Once the buffer is full, the oldest events will fall from the buffer and get replaced by any new events. Refer to Event Codes section under Fault Diagnosis for code descriptions.

SETTING SCREEN

To enter a passcode, use the navigation buttons left and right to change digits and up and down to change the value.

Entering the default passcode **0 0 0** gives access to the Time & Date settings screen.

Entering the default passcode **1 2 3** gives access to the TCP/IP settings screen.

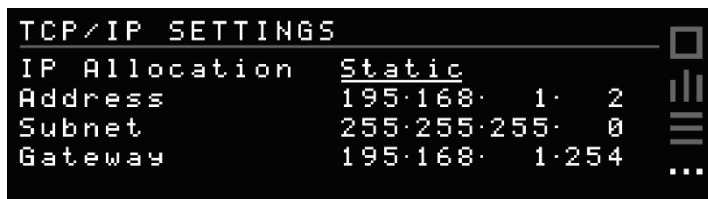
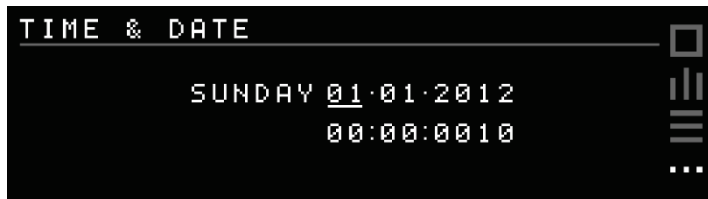

IP Allocation can be set to Static and entered manually, or set to Dynamic (DHCP) where the device will be assigned an IP address automatically. Refer to the Web Interface section for instructions on accessing advance settings.

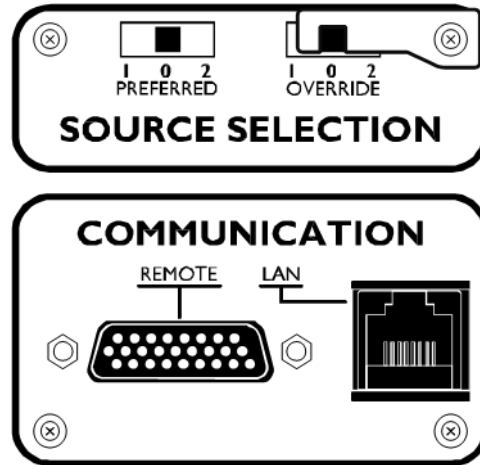

4.3 Preferred Switch

This switch allows the preferred source to be set to Supply 1, Supply 2 or None (0), which will take affect only when the preferred source is set to None (0) on the iSTS software. Refer to the Web Interface section for instructions on changing the preferred source through LAN connectivity.

If the iSTS has transferred the critical load to the alternate source, the iSTS will automatically transfer back to the preferred again when the preferred source is within tolerance and after a pre-set settling delay, typically 4 seconds.

4.4 Override Switch

Setting the override switch to 1 or 2 will force the iSTS to stay on that supply even if faults are detected on that source. This switch overrides all other settings. It should not be used to transfer the critical load between sources (a break may result).

NOTE: The override provides control logic bypass only, it does not provide an alternative path for the load power.

WARNING! The override switch initiates instantaneous transfers and may transfer faults to the load.

WARNING! Never attempt to operate the OVERRIDE switch if the supplies are not in synchronism. There is no interlock to prevent the switch from being operated when the supplies are not available or not in synchronism. Refer to the LCD variables display and mimic diagram to check the synchronism state, (SYNC LED will be RED, variables display will show degrees out of synchronism. Only operate when less than 10 degrees).

If the control is not operating you may need to use other means to determine that the supplies are in synchronism. Do not operate the OVERRIDE switch onto an absent supply.

4.5 Remote Connection Port – High Density DA-26

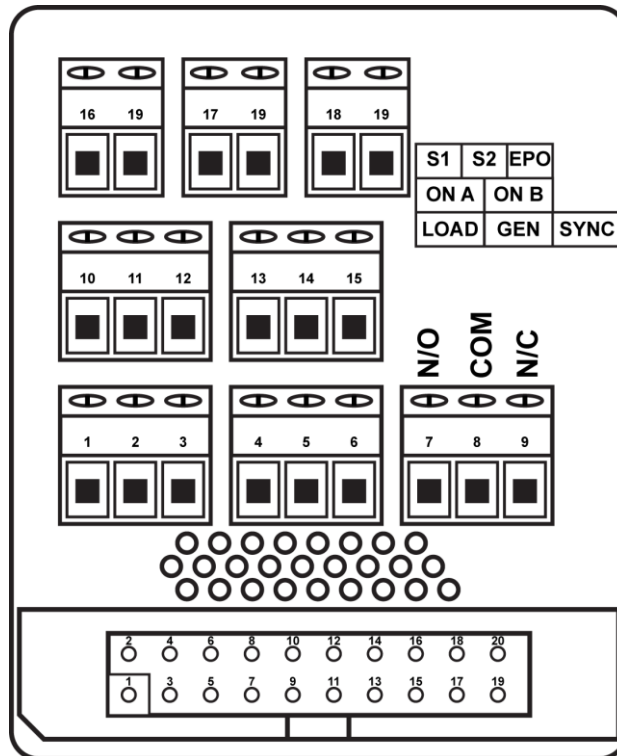

The relays can switch up to 50VAC/DC - 2A and are not suitable for 110/240V or other applied voltages. Remote contacts are wet contacts and do not require external voltage to be applied.

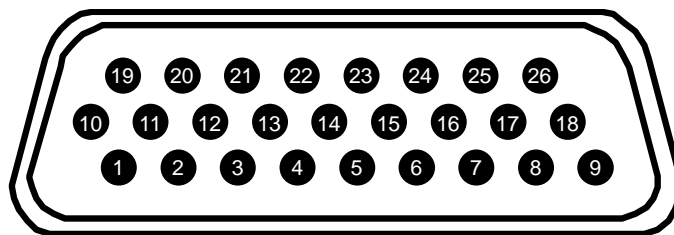

PINS	CONNECTION	FUNCTION
1 to 2	Normally Open	Load Fault
3 to 2	Normally Closed	Load Fault
4 to 5	Normally Open	General Alarm
6 to 5	Normally Closed	General Alarm
7 to 8	Normally Open	Not in Sync
9 to 8	Normally Closed	Not in Sync
10 to 11	Normally Open	ON B (Supply 2)
12 to 11	Normally Closed	ON B (Supply 2)
13 to 14	Normally Open	ON A (Supply 1)
15 to 14	Normally Closed	ON A (Supply 1)
16 to 19	REMOTE CONTACT	Emergency power off
17 to 19	REMOTE CONTACT	Transfer to Supply 1
18 to 19	REMOTE CONTACT	Transfer to Supply 2

4.6 Confirm Operation

1. Press the Preferred Button to highlight 'I' on the Preferred Indicator. Wait for the STS to transfer to Supply 1, if it is not already on Supply 1. On Supply 1 LED will turn green.
2. Turn off Supply 1. Confirm that the STS transfers to Supply 2. On Supply 2 LED will turn green.
3. Turn on Supply 1. Confirm that the STS automatically transfers to Supply 1 after a 3 second delay. On Supply 1 LED will turn green.
4. Press the Preferred Button to highlight 'II' on the Preferred Indicator. Wait for the STS to transfer to Supply 2. On Supply 2 LED will turn green.
5. Turn off Supply 2. Confirm that the STS transfers to Supply 1. On Supply 1 LED will turn green.
6. Turn on Supply 2. Confirm that the STS automatically transfers to Supply 2 after a 3 second delay. On Supply 1 LED will turn green.
7. The operational test is complete. You can now select a preferred supply if any.

5. MAINTENANCE BYPASS

5.1 Overview

Maintenance Bypass mode allows the load to be connected to one supply without going through the power circuit of the STS.

The maintenance bypass switch is located on the front of the power module. The switch is normally in the "N" position and can be used to bypass the internals of the STS to either "Supply Source 1" or "Supply Source 2".

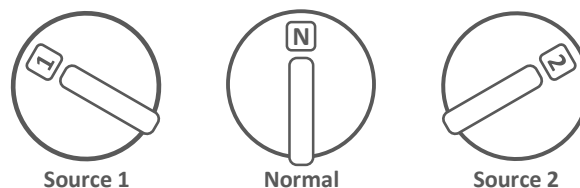

THE MAINTENANCE BYPASS SWITCH SHOULD ONLY BE USED TO SELECT THE PRESENTLY OPERATING SOURCE. IT CANNOT BE USED TO TRANSFER THE CRITICAL LOAD FROM ONE SOURCE TO THE OTHER.

The maintenance bypass switch utilises make-before-break switching, incorrect operation of the maintenance bypass features could result in dangerous voltages occurring and short circuits.

Note: A padlock can be used to stop inadvertent or unauthorized operation of the switch.

5.2 Maintenance Bypass Procedure

Bypass Mode on Supply 1

1. Use the TRANSFER pushbutton on the front of the unit to transfer the load to Supply 1.
2. TURN OFF Supply 2 using the isolator switch on the front of the unit.
3. Finally operate the Maintenance Bypass Switch by turning to position 1. The unit will now be in bypass mode on Supply 1.

Bypass Mode on Supply 2

1. Use the TRANSFER pushbutton on the front of the unit to transfer the load to Supply 2.
2. TURN OFF Supply 1 using the isolator switch on the front of the unit.
3. Finally operate the Maintenance Bypass by turning to position 2. The unit will now be in bypass mode on Supply 2.

Removing the Power Module

Once the unit is in maintenance bypass mode on either Supply 1 or 2, the power module can be removed. To remove the module, make sure the bypass cradle is secure then use the tabs on the sides of the module to pull it out from the cradle.

5.3 Reinstatement from Maintenance Bypass

1. Push the power module into the cradle. Take care to ensure the connectors on both parts are aligned and the cradle and module are mated together securely.
2. Turn on both Supply 1 and Supply 2 circuit breakers located at the front of the unit. Wait for the unit to start up. The mimic on the display screen should show Supply 1 and 2 as GREEN to indicate that both supplies are active in the STS.
3. Move or operate the Preferred Source selection switch to the supply that is in bypass.
4. Check the mimic LEDs and ensure that the STS and the maintenance bypass LEDs are the same (GREEN).
5. Finally operate the bypass switch, returning it to the middle position.
6. The unit will now be normal operation mode.

6. WEB BROWSER INTERFACE

Connecting to the LAN interface can be done two different ways with a RJ45 Cat5 Ethernet cable:

- To a Network hub/switch using a straight-through cable.
- To a PC using a cross-over cable (most PCs can now work with a straight-through cable).

6.1 Connection to a Network

By default the STS uses a Static default IP address of 192.168.1.2, however, if required from the display or the HTTP interface a DHCP can be selected to have the IP information assigned automatically after the Ethernet cable is plugged in at both ends, this process can take up to several seconds to complete. If your network does not have a DHCP server or if you wish to use a static IP, you can change the IP Allocation on the Communications Settings screen shown below (or the Control Panel page on the Web server).

Use navigation buttons on the unit and move to the Settings menu, enter the passcode **1 2 3** to access TCP/IP settings. Setting IP Allocation to Static allows for manual input of IP address, subnet and gateway.

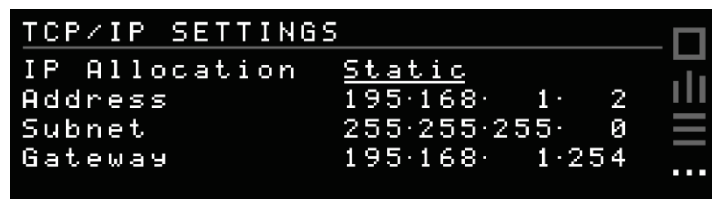

COMMUNICATION SETTINGS

6.2 Connecting to a PC

When connecting directly to a PC, both the STS and PC must have statically assigned IP addresses on the same subnet. Set the IP address of the STS in the Communications screen described earlier. By default this is IP: 192.168.1.2 with Mask: 255.255.255.0

To set the IP address of your computer in Windows 7 go to: Network and Sharing Centre ► Change adapter settings, right-click the network interface ► Properties. Select TCP/IPv4 ► Properties. Change the values to match as shown below and click OK, you soon should be connected to your device.

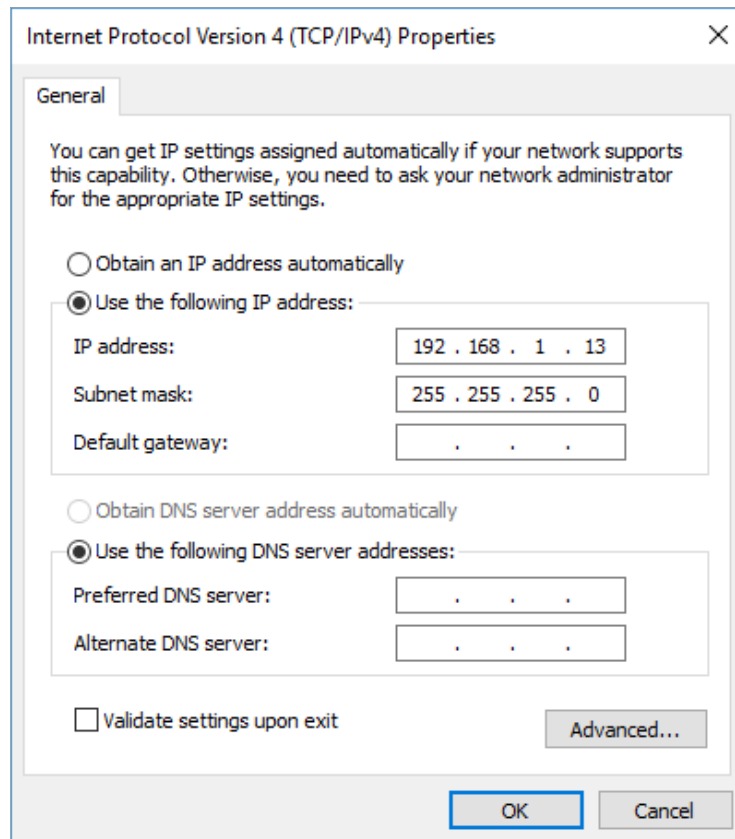

For other operating systems, please refer to the OS networking manual.

6.3 Connecting to the Web Server

To use a ping test to confirm the connection on a PC, run command prompt (CMD) and type ping (space) then the IP address of the device then press enter.

Entering the IP address into the web browser address bar brings up the web server home page. If the DHCP / address have not yet been registered on your network you may need to remove the cable for 5 to 10 seconds and reconnect the cable, this in turn should re-register the device on the network.

Supply 1 Online**No Supply Preference**

Variables

	L1	L2	L3
Supply 1(V)	224	226	229
Supply 2(V)	226	224	229
Output:			
Voltage	226	197	227
Current(A)	24	22	25
Power(kVa x10)	56	45	57
Power(kW x10)	55	44	56
Power Factor	0.98	0.98	0.98

Events

<< < > >> ⌵

Date	Time	Event	Target
16/04/2018	15:51:04	S3 Average V	OK
16/04/2018	15:51:04	S3 Average V	OK
16/04/2018	15:51:04	S3 Average V	OK
16/04/2018	15:51:04	Transfer	1
16/04/2018	15:50:59	S3 Average V	L3
16/04/2018	15:50:59	S3 Average V	L2
16/04/2018	15:50:59	S3 Average V	L1
16/04/2018	15:50:59	Initialise	

[Open Control Panel](#)

WEB SERVER HOME PAGE

The home page displays the connected supply, supply preference, variables and events list that can be scrolled through using the arrows provided. From the home page, gain access to the Control panel by clicking Open Control Panel and enter following username and password:

Username: **admin**

Password: **1234**

6.4 Control Panel

On the Control Panel page, many more options become available:

- Viewing utilisation
- Ability to transfer supply
- Setting the preferred supply
- Setting the name and location information
- Adjusting the time and date
- Setting the IP address

NOTE: You must press update for the information to be saved on the device

The screenshot shows a control panel interface with the following sections:

- Control Panel Header:** Tabs for Control, Email, and Settings. A close button (X) is in the top right.
- Utilisation:** A table showing operational statistics.

Total Hours on Supply 1	0	Number of Synchronisation Losses	2
Total Hours on Supply 2	0	No of Load Fault	3
Total Hours on Preferred Supply	0	Last Load Fault	01/01/2012 00:00:00
Total Hours in Operation	0	No of Supply Outages	0
Number of Hours with no output	0	Last supply outage	13/02/2012 23:51:28
Number of Forced Transfers	3	Model Number	
- Supply:** A green button labeled "Transfer Supply ↻".
- Set Preferred:** Radio buttons for "1", "None", and "2".
- Eco Mode:** Radio buttons for "ON" and "OFF".
- Unit Details:** Input fields for "Name:" (containing "NAME") and "Location:" (containing "LOC"), with an "Update" button.
- Network:** DHCP mode set to "Off". IP address: 192.168.1.2, Mask: 255.255.255.0, Gateway: 192.168.1.254. Includes an "Update" button.
- Time & Date:** Time: 0:10:00 (Hour: 0, Minute: 10, Second: 0), Date: 1/1/2012 (Day: 1, Month: 1, Year: 2012). Includes an "Update" button.

CONTROL PANEL SCREEN

Transferring the Supply

Clicking on the "Transfer Supply" will change to the alternate supply after a few seconds refresh the browser to view the new status. If that supply is faulty the transfer will not occur.

Set Preferred

The iSTS will stay connected to the preferred supply until there is a failure. In the case of the supply failing, the STS will switch to the alternate supply and then switch back to the preferred after the fault has cleared and the incoming AC voltage has returned to normal. When None is selected, the iSTS will not revert back to the other supply after switching.

Unit Details

Enter a name for the device under "Name:" and the location it is stored at under "location:" this should be done so you can differentiate between different static transfer switches.

Date and Time Settings

Enter the date and time, this should only be required once. We strongly encourage setting the correct time and date so that the real time event correlation can be undertaken. After pressing update the details will be stored into the unit. The real time clock is thereafter backed up by a battery cell

IP Address Settings

The default settings is set to DHCP mode "On", when this is set to "Off" then the other options become available to change. From here you can change the IP, Mask and the Gateway. After pressing update these details will be saved on the unit.

6.5 Email

The Email tab allows you to turn on the email notification service. When a certain event occurs the unit will send an email to notify the user. The email takes the following format:

STS01 – LVL5
Supply 1 Fault - 05/05/2014 13:01:42

Server Settings

This is the SMTP server that the unit will use to send the email. You need to provide the Server Address, Server Port, User name or email, and a password.

Note: this cannot be an SSL SMTP server.

Recipient Email

This is where the email notification will be sent. It can be the same as the above email.

Email List

In this section you can select which event types should trigger an email notification to be sent.

Control **Email** **Settings** ×

Email Notifications

ON OFF Set

Settings

Server Address:

Server Port:

User name / Email:

Password:

Recipient Email:

Save

Email List

<input type="checkbox"/> Input/Output Faults	<input type="checkbox"/> Load/Current Warnings
<input type="checkbox"/> Frequency and Synchronisation	<input type="checkbox"/> Force/Override
<input type="checkbox"/> Preferred Supply Change	<input type="checkbox"/> User Transfers Warnings
<input type="checkbox"/> Bypass	<input type="checkbox"/> SCR/Thyristor
<input type="checkbox"/> Heat Warnings	<input type="checkbox"/> Power Supply Faults
<input type="checkbox"/> Transfer Inhibit	<input type="checkbox"/> Breaker Changes

Set

EMAIL SCREEN

6.6 Advanced Settings

Control

Email

Settings

✕

Input Steady State

S1 steady state high value (%) 105 - 135

S1 steady state low value (%) 70 - 95

S2 steady state high value (%) 105 - 135

S2 steady state low value (%) 70 - 95

Steady state failure time (sec/10) 10 - 30

Phase error detection normal (deg)

Phase error detection fault (deg) D (5-180)

Phase error detection break (ms) 0 - 150

Input Transient

S1 transient high value (%) 105 - 135

S1 transient low value (%) 70 - 95

S2 transient high value (%) 105 - 135

S2 transient low value (%) 70 - 95

Re-transfer timeout (sec) 5 - 25

Re-transfer max attempts 0 - 5

Output

Output steady state high value (%) 105 - 135

Output steady state low value (%) 70 - 95

Output transient high value (%) 105 - 135

Output transient low value (%) 70 - 95

High current time (minutes)

High current time (secs)

Transfer timer 0 - 100

SETTINGS SCREEN

NOTE: The STS has been shipped with factory defaults. These are the most reliable settings for correct stable operation. These settings should only be changed under the certain operating conditions and it is advised that you consult with us before doing so, as wrong settings can make the system unstable and damage equipment.

6.7 Input Steady State Settings

These figures define the upper and lower limits of deviation from the nominal voltage and current of the input power that creates the fault condition to trigger the alarm and record the event.

S1 steady state high value (%)

Default value of 115%, can be changed from a nominal value of 105 to 125. This number will be set as percentage.

Averaging time constant for this parameter is defined by Steady state failure time typically 1.5 seconds.

S1 steady state low value (%)

Default value of 85%, can be changed from a nominal value of 70 to 95. This number will be set as percentage.

Averaging time constant for this parameter is defined by Steady state failure time typically 1.5 seconds.

S2 steady state high value (%)

Default value of 115%, can be changed from a nominal value of 105 to 135. This number will be set as percentage. Averaging time constant for this parameter is defined by Steady state failure time typically 1.5 seconds.

S2 steady state low value (%)

Default value of 85%, can be changed from a nominal value of 70 to 95. This number will be set as percentage.

Averaging time constant for this parameter is defined by Steady state failure time typically 1.5 seconds.

Steady state failure time (sec/10)

Default value of 15, this value will be divided by 10 making the value of 1.5 seconds. This number can be between 10-30. This is the amount of time for the input power sources being outside of the limit values in order for the fault condition to be determined as true. If this time is set to too small of a value it can cause erratic operation.

NOTE: By default the unit operates with the intelligent out of sync delay. To turn off the intelligent sync delay DIP SW2 must be turned on. The below phase settings should only be changed when intelligent sync delay is off.

Phase error detection normal (deg)

This figure between 0 – 180 degrees, sets the maximum allowable separation between the two supplies, whereby if the supplies fall out of phase by this amount, the user will no longer be able to perform a manual transfer. The default is 10 degrees.

Although the setting limit can be set from 0 to 180 degrees the consequence of transfer when asynchronous may result in a non-seamless transfer to the critical load. Ferromagnetic devices will saturate and draw large current when out of synchronism transfers are undertaken. The effect on some switch mode power supplies is also unknown. The user should consult with the equipment manufacturer to ensure that damage does not result from out of synchronisation transfers and what their recommended synchronisation limits are.

Setting to “0” disables the transfer pushbutton operation.

If the programmed value in the “Auto” column is exceeded no action takes place. Refer to “Phase error detection fault” below.

Phase error detection fault (deg)

This is the degree of difference between phases of the supplies that will force a break time between automatically initiated transfers due to supply source / output supply faults.

The default value is “D” (Dynamic) which means the STS will calculate the break to insert for the degree of asynchronisation.

This can be set from 5 to 180 degrees. The recommended default is 30 degrees. Up until this value transfers that are initiated from the system (except manually) will occur without a break. Once the displacement between the two phases is more than this value, a break is inserted as defined by “Phase error detection break”.

Phase error detection break (ms)

Setting this value to '0' turns on the intelligent transfer delay mode where the device will automatically calculate a break time based on the degree of difference between the two supplies. For more information refer to 'Prevention of Transformer Saturation' technical report.

Otherwise this can be set from 10 – 150 msec with resolution of 10 msec. These are typical break insertion times; additional time would be added as a result of thyristor turn-off delays.

NOTE: In the scenario that two supplies are significantly out of synchronism, a break time will be insert to prevent inadvertent damage to equipment, tripping of protection devices or opening of fuses.

6.8 Input Transient Settings

These figures define the upper and lower limits of deviation from the nominal voltage and current of the input power that creates the fault condition to trigger the alarm and record the event.

S1 transient high value (%)

Default value of 115%, can be changed from a nominal value of 105 to 135. This number will be set as percentage. Transient time constant for this parameter is defined by "transient over-sampling time constant 3 x 312 μ sec".

S1 transient low value (%)

Default value of 85%, can be changed from a nominal value of 70 to 95. This number will be set as percentage. Transient time constant for this parameter is defined by "transient over-sampling time constant 3 x 312 μ sec".

S2 transient high value (%)

Default value of 115%, can be changed from a nominal value of 105 to 135. This number will be set as percentage. Transient time constant for this parameter is defined by "transient over-sampling time constant 3 x 312 μ sec".

S2 transient low value (%)

Default value of 85%, can be changed from a nominal value of 70 to 95. This number will be set as percentage. Transient time constant for this parameter is defined by "transient over-sampling time constant 3 x 312 μ sec".

Re-transfer timeout (sec)

This parameter defines the delay before a re-transfer back to the original preferred source after the fault has been cleared and the source has returned to normal steady state conditions. The default value for this parameter 5 seconds. If this is set to a value too small, an unstable condition could arise from the source not having enough time to recover.

Re-transfer max attempts

This setting refers to the number of times the device will transfer back to the preferred source. A lock out results after this but is re-set on a new fault alarm condition. The default value is 3. A setting of "0" inhibits retries and device will not transfer back to the preferred source.

NOTE: Adjustment may be required to the Transient values if the source supply voltages are distorted or above or below nominal. Setting too close a limit to the actual operating Steady State voltage may cause erratic Static Transfer Switch operation.

6.9 Output Settings

Output steady state high value (%)

The default value of 118%, can be changed from a nominal value from 105 to 135. This number will be set as a percentage.

Averaging time constant for this parameter is defined by “Steady-state failure time” typically 1.5 seconds.

Set as a percentage from nominal – This parameter should always be wider than the S1 & S2 Steady state high threshold. This will ensure that when there is a problem with S1/S2 the event list will report correctly. S3 (Output) sensing is provided as redundant sensing for online source S1 or S2 and in case of internal thyristor triggering a fault.

When the output reaches this value the alarm will be triggered and the STS will transfer to the alternative source.

Output steady state low value (%)

A default value of 82%, can be changed from a nominal value of 70 to 95. This number will be set as a percentage. Averaging time constant for this parameter is defined by “Steady-state failure time” typically 1.5 seconds. Set as a percentage from nominal – This parameter should always be wider than the S1 & S2 steady state low threshold. This will ensure that when there is a problem with S1/S2 event list will report correctly. S3 (Output) sensing is provided as redundant sensing for online source S1 or S2 and in case of internal thyristor triggering a fault.

When the output reaches this value the alarm will be triggered and the STS will transfer to the alternative source.

Output transient high value (%)

The default value of 120%, can be changed from a nominal value of 105 to 135. This number will be set as a percentage. The transient time constant for this parameter is defined by “Transient over-sampling time constant $2 \times 312 \mu\text{sec}$ ”. Set as a percentage from nominal – This parameter should always be wider than the S1 & S2 transient high threshold. This will ensure that when there is a problem with S1 or S2 the event list will report correctly. S3 (Output) sensing is provided as redundant sensing for online source S1 or S2 and in case of internal thyristor triggering a fault. The operation is to transfer to the alternative source.

Transient limits should be set outside Steady state limits.

Output transient low value (%)

The default value of 80%, can be changed from a nominal value of 70 to 95. This number will be set as a percentage. The transient time constant for this parameter is defined by “Transient over-sampling time constant $2 \times 312 \mu\text{sec}$ ” This parameter should always be wider than the S1 & S2 transient high threshold. This will ensure that when there is a problem with S1 or S2 the event list will report correctly. S3 (Output) sensing is provided as redundant sensing for online source S1 or S2 and in case of internal thyristor triggering a fault. The operation is to transfer to the alternative source.

Transient limits should be set outside steady state limits.

High current time (minutes) at 110% & 125% Overload

The default values for 110% (first column) is 60 minutes and for 125% (second column) is 20 minutes. Exceeding the overload limits of 110% for greater than 60 minutes OR 125% for 20 Minutes will not affect the critical load and no switching occurs. It is intended as a warning that the STS is overloaded. Failure to reduce the load will cause semiconductor failures.

Consult the manufacturer before setting to higher values to ensure that the unit will operate safely without failure or overheating.

High current time (secs) at 150% & 200% Overload

The default values for 150% (first column) is 10 seconds and for 200% (second column) is 1 second. Exceeding the overload limits of 150% for 10 seconds OR 200% for 1 second will not affect the critical load and no switching occurs. It is intended as a warning that the STS is overloaded.

Failure to reduce the load will cause semiconductor failures.

Transfer timer

The default setting value is “0” which disables this function.

This parameter sets a period in seconds that the STS will undertake a test transfer to the alternate source. After a delay, the load will be returned to the original source. This function is used to test functionality and protections within the STS.

7 FAULT DIAGNOSIS

7.1 Fault Codes

Event	Append	Description	STS Action Resulting
INIT		RAM CHKsum failed – Cold Start (RAM Corrupt) – Flash Defaults downloaded	None - Contact Static Power
WARM BOOT		Power-up, Warm Start, re-initialize all but RAM – Keeps Event List	Normal After Black Start
SYNC	FLT/OK/WRN	S1 & S2 not in synchronism	Alarm No action
SUPPLY 1	FLT/OK	Supply 1 has a fault or fault has cleared	When fault is detected transfers to supply 2 if on 1
SUPPLY 1 TRANS		Supply 1 has Transient High or Low (1 sec)	Transfers to supply 2 if on 1
SUPPLY 1 AVG	LOW/HIGH/OK	Supply 1 steady state is outside tolerance limits	When fault is detected, transfers to supply 2 if on 1
SUPPLY 2	FLT/OK	Supply 2 has a fault or fault has cleared	When fault is detected transfers to supply 1 if on 2
SUPPLY 2 TRANS		Supply 2 has Transient High or Low (1 sec)	Transfers to supply 1 if on 2
SUPPLY 2 AVG	LOW/HIGH/OK	Supply 2 steady state is outside tolerance limits	When fault is detected, transfers to supply 2 if on 1
SUPPLY 3 AVG		Output steady state is outside tolerance limits	Transfers to inactive supply
SUPPLY 3 TRANS		Outside has Transient High or Low (1 sec)	Transfers to inactive supply
CURRENT	WARN/HIGH	Output is overloaded (timed shutdown)	Alarm No action starts timer
TRANSFER	1/2	Transfer to Supply 1 or 2 requested	User - Manual Action
PREF	1/2/OFF	Preferred Source Set 1, 2 or none	User - Manual Switch Only
SCR SC	1/2	SCR on S1 or S2 short circuit detected on Supply 1 or 2	Contact Static Power – Locks to safe source
SCR OC	1/2	SCR on S1 or S2 Open circuit detected on phase #	Contact Static Power – Locks to safe source

7.2 Load Fault

Transfer timer

In case of sustained high current output load faults, the iSTS will inhibit a transfer to the alternate supply even if this means degradation or loss of source supply. It is therefore imperative that you ensure that the discrimination with downstream and upstream protective devices ensures that the downstream protective device always clears the fault first. The transfer inhibit timer will automatically reset after 90 seconds.

In case that all output is lost the faulty equipment should be located and removed from the iSTS output before re-instatement of power.

8. RECOMMENDED MAINTENANCE SCHEDULE

If the unit is faulty then it should be removed from service as per the accompanying procedure and a qualified experienced service agent should affect repair.

- Once per month record the operating variables and compare with the specifications and operating parameters to ensure that the unit is operating correctly.
- Check the Event History and correlate any recorded events since last observation with real occurrences. Report / investigate any suspicious entries.
- Once every 6 months, (sooner if the environment is bad), vacuum dust from grills at front of unit.
- Inspect cable connections for overheating.
- Units with fans need their fans changed every 3 - 5 years. This may need to be sooner if the environment is bad.

Contact Static Power for help with troubleshooting and parts replacement.

NOTE: The user should not undertake repair procedures or gain access to the internal of the equipment.

9. SPECIFICATIONS

Current rating	1Ph: 125A max 3Ph: 63A max
Voltage rating	All region-specific voltages $\pm 10\%$
Type	1-Phase/2-Pole, 3-Phase/3-Pole or 3-Phase/4-Pole
Frequency	50Hz and 60Hz, $\pm 10\%$ - Auto detection
Transfer type	Break-Before-Make zero current transfer by Thyristors / SCR
Synchronous break time	<1ms - asynchronous break time up to $\frac{1}{4}$ cycle
MTBF	>800,000 hours
Maintenance bypass	Cradle with 3-position overlapping, no-break CAM switch
Isolation	Incoming sources isolator switches
Display	Bi-colour LED mimic decal with graphic OLED display and information interface
Interface	Preferred supply selection, Source transfer selection and Alarm cancel button
Contact	2/3 Self wetting transfer control inputs 5 Pre-defined Voltage free change-over status indicators, Form C
Ethernet	HTTP, SNMP, MODBUS TCP, Email & NTP - <i>Modbus RTU Optional</i>
Input options	Fixed wiring to terminals up to 16mm ² cables via glands - 35mm ² for single phase 125A
Output options	Fixed wiring to terminals up to 16mm ² cables via glands - 35mm ² for single phase 125A
Dimensions H x W x D	2RU/19" - 88 x 483 x 460mm
Weight	16kg
Temperature	0 – 45°C
IP rating	IP31
Detection	Digital: <1ms
Asynchronous break time	0ms, 10ms, 50ms or Vt proportional, 0° to 180°
Loading	0 - 100% @45°C ambient
Device ratings	134A _{RMS} , 1600V, 2kA 1 cycle
Overload @40°C ambient	125A for 30s 140A for 1s 250A for 0.1s 2kA for 1 cycle
Fault current setting	300% peak with load fault transfer inhibit
Safe install environment	20kA, 100A/200A internally fused
Protection	100A/200A fuses - BS88/FE100
Power factor	No practical limit
Max THDV	10% - Max allowable source voltage distortion
Crest factor	3.5 : 1
dV/dt max	800V/ μ s
Cooling	Redundant fans
Humidity @40°C ambient	5 – 95% non-condensing
Regulatory approvals	IEC 62310-1,2,3 - IEC 60950 - IEC 61000-6-1,2,3,4 – CE – RCM - UL Capable - RoHS
Standard warranty	24 months offsite repair or replacement policy

Specifications are subject to change without notice

